

DUPRINTER

DP-43E/33E/31E

Instruction Manual

Ver. 1

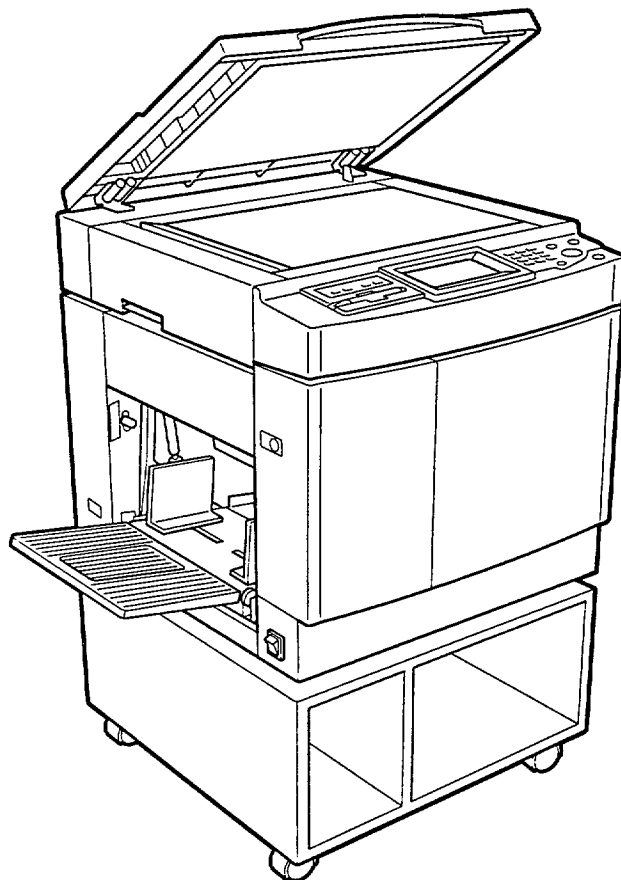

Correct operation and periodic maintenance are essential for ensuring safe use of this machine. Thoroughly read this manual before using this machine.

DUPLO CORPORATION

Store this manual so that it can be retrieved whenever needed.

CONTENTS

Introduction	1
Conventions Used in This Manual	1

1. Before Using the Machine

Safety Precautions	4	System Setup	12
Positioning the Machine	8	Part Names and Their Functions	13
Cautions	8	How Platemaking and Printing is Carried Out	18
Maintenance	9	Platemaking	18
Printing and Duplicating Cautions	10	Printing	18
Document/Copy paper Specification	11		

2. Platemaking and Printing Procedure

Preparations	19	Checking the Control Panel	22
Placing the Paper	19	Placing the Document	23
Setting the Paper Stacker	20	Selecting the Paper Size	24
Turning the power ON	22	Platemaking	25
Platemaking	22	Making Prints	25

3. Various Functions

DISPLAYING THE STATUS	26	Entering the Number of Prints and Number of Sets	49
Test Printing	27	Print	50
Adjusting the Platemaking Density (darkness)	27	Sectional Printing	
Adjusting the Print Density		(dividing sections with tape)	50
(ink transfer amount)	30	Enter the Number of Prints and Number of Sets	51
Adjusting the Printing Speed	31	Print	52
Adjusting the Printing Position (vertical)	32	Sectional Printing	
Adjusting the Printing Position (horizontal)	34	(changing the number of prints with each	
Using a Thick or Thin Paper (adjusting the feed		document)	53
pressure)	36	Multiple Image Printing	
Enlargement/Reduction	37	(on one sheet from the same document)	54
Enlarge/Reduction		Printing with Two documents (ADF)	56
(standard size → standard size)	37	Confidential Safeguard Function (preventing	
Slight Reduction (94%)	38	others from making copies)	59
Auto Zoom Function		Total Counter (displaying the total number of	
(printing matched to the paper size)	40	plates and prints made)	61
Zoom Setting Function		Special Functions	62
(printing at a specified zoom factor)	42	Fine Start	62
Printing Photographs/Color Documents	45	Auto Clear	64
Erasing Book Shadows		Preprint	65
(printing documents with shadows on the center		Print Number Input Mode	67
or the edges erased)	47	Change Initial Setting	68
Sectional Printing (stopping after each set)	48		

4. Function Mode

Function Mode Screens and Their Features	70	Calling	73
Function Mode Screen	70	Clearing	74
Saving	72	Modifying Number of Copies/Sets	75

Introduction

Thank you for your purchase of the Duprinter DP-43E/DP-33E/DP-31E.

To ensure safe and efficient prolonged use of this machine, read and thoroughly understand this manual before using this machine. After using this manual, be sure to keep it in a place to handy reference.

Conventions Used in This Manual

About Machine Safety

Various symbols and pictures are used in this manual and on the stickers affixed to the machine. These symbols and pictures provide warnings and instructions to prevent danger to you or other personnel, and to prevent damage to office property. The meanings of these symbols and pictures are explained below.



WARNING: Indicates a high degree of potential danger. If the warning is ignored, death or serious injury may result.



CAUTION: Indicates a medium degree of potential danger. If the caution is ignored, medium injury or damage to property may result.

Examples of Pictorial Symbols



⊘ A circle with a line through it indicates a prohibited action. The particular act prohibited is indicated by a picture inside the circle. (In the example shown here, the prohibited act is disassembly.)



● A black disc indicates an instruction, or sometimes a prohibited action. The instruction itself is indicated by pictorial symbols drawn in white on the disc. (In the example shown here, the instruction is “Remove the plug from the outlet.”)

Other Notifications Used in this Manual



Introduces instructions for correct operation of the machine. If these instructions are ignored, the machine may not be able to operate at optimum performance, or may break down.



Introduces information that is useful for operation and maintenance of the machine, or information about the machine's performance, etc.

PLEASE NOTE

In the interest of upgrading our products, specifications and other data given in this manual are subject to change without notice. If the manual contains anything that you do not understand, contact the manufacturer for clarification.

5. Editing Functions

Pen Input (Area Specification) -----	78	Photograph Mode (Making Plates for Photographs)	91
Specifying a Box Area -----	78	Masking Mode (Deletes Part of a Document) -----	95
Specifying a Polygonal Area -----	80	Outline Type (Changes Ordinary Text to Outline Type)	
Specifying an Area by Painting It -----	83	And Patterns (Inserts Designs)-----	101
Zoom/Move -----	85	Reversing Mode (Reverses The Video (Monochrome)	
Zoom/Move Functions -----	85	on a Portion of a Document) -----	106
Zooming -----	85	Adding Makeup -----	110
Moving -----	88	Switching the Masking Area -----	112
Makeup -----	89	Trimming -----	113
Makeup Functions -----	89		

6. Replacing Consumables

Changing the Ink Pack -----	117	Replacing the Drum Unit -----	124
Replacing the Master Roll -----	119	Removing the Drum -----	124
Replacing the Master Ejection Core -----	123	Setting the drum unit -----	125

7. Options

Tape cluster -----	127	Sorter -----	131
ADF -----	128	Sort mode -----	131
Documents that are accepted by ADF -----	128	Group Mode -----	132
Platemaking and Printing -----	128	Non-sort Mode -----	133
Key Card Counter -----	129	How to Use The Sorter -----	133
Handling Cards -----	130	Interface -----	135

8. Troubleshooting

Power Does Not Turn ON -----	136	To replace with a different size of paper -----	141
Platemaking/Printing is Not Possible -----	136	Paper Jam (feeder side) -----	142
Error Messages -----	137	Paper Jam (ejection side) -----	144
If Paper Runs Out during Printing -----	139	Paper Adhering to Drum -----	145
If paper runs out during printing, printing stops and		Master is Not Ejected -----	147
the paper tray is lowered automatically -----	139	Master Set Incorrectly -----	149
To add more paper to an almost empty stack during			
printing -----	139		

9. Specifications, Maintenance ----- 151

Warranty and Maintenance Service -----	153
--	-----

Quick Operation Guide ----- 154

1. Before Using the Machine

Safety Precautions

These are particularly important safety points and should always be observed.

WARNING

If the machine is used after foreign matter (metal fragments, water, or liquid) has entered the machine, this may result in fire or electric shock.

- Turn the main unit's power switch OFF, and then remove the power plug from the outlet. Contact the sales distributor.

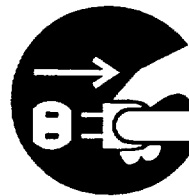

If the machine is used after heat, smoke, strange smell, or other abnormality is detected, this may result in fire or electric shock.

- Turn the main unit's power switch OFF, and then remove the power plug from the outlet. Contact the sales distributor.

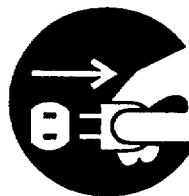

Connect the machine to ground. If a short occurs while the machine is not grounded, this may result in fire or electric shock.

- If you cannot ground the machine, contact the sales distributor.

Grounding Measures

- Connect the ground lead to the earth terminal on the outlet.

*Do not connect the machine ground lead to gas pipes.



Do not modify the machine.

- Doing so may result in fire or electric shock.

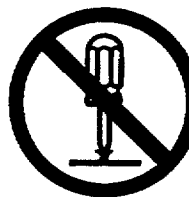

Do not remove the rear lid, cabinet, or covers from the machine.

- The inside of the machine contains high-voltage parts, which may cause electric shock.





WARNING

Do not remove or insert the power plug with wet hands.

- Doing so may result in electric shock.

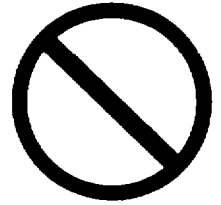

Do not damage, break, or modify the power cord.

- Do not place heavy objects on, tug, or unnecessarily bend the power cord. Doing so may result in fire or electric shock.

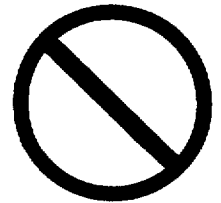

Do not insert or drop metal, flammable material, or other matter through the ventilation holes into the machine interior.

- Doing so may result in fire or electric shock.

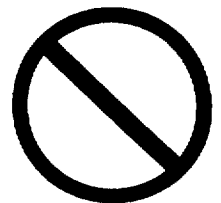

Do not place flower vases, flowerpots, cups, or water containers (including metal containers) on top of the machine.

- Fire or electric shock may result if liquid spills inside the machine

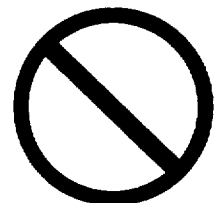

Do not use a source voltage other than that specified. Do not connect two or more loads to a single outlet.

- Doing so may result in fire or electric shock.



Do not place the machine in a humid or dusty area.

- Doing so may result in fire or electric shock.



! **CAUTION**

Before moving the machine, remove the power plug from the outlet.

- If the cord is damaged, this may result in fire or electric shock

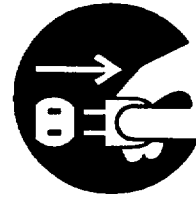

Remove the power plug itself, not the cord.

- Tugging the cord may damage it (expose conductors, or cause disconnections, etc.), resulting in fire or electric shock.

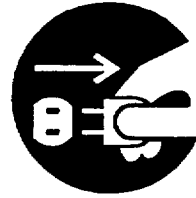

Do not place the machine in an unstable position, such as on an unsteady support or sloping area.

- If the machine is dropped or falls over, this could result in personal injury.

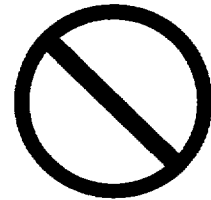

Once the machine is in position, secure in place using the casters.

- If the machine falls over, this could result in personal injury.

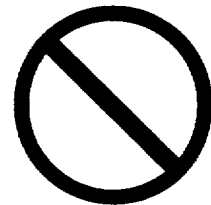

Keep the WARNING and CAUTION stickers clean at all times. If stickers become damaged or come off, replace them with new ones.

①

Warning Do not remove this cover. The inside of the printer contains movable cutting instruments, contact with which could result in injury.

J3/T 13200

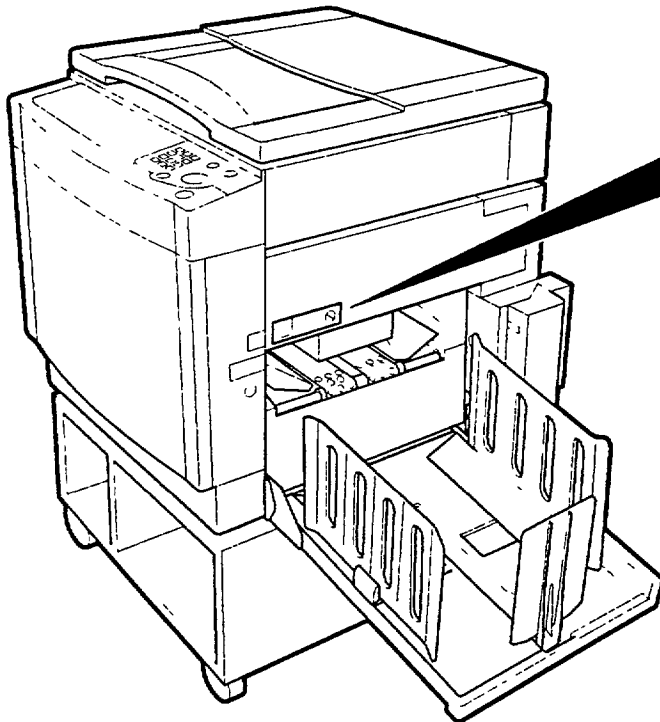
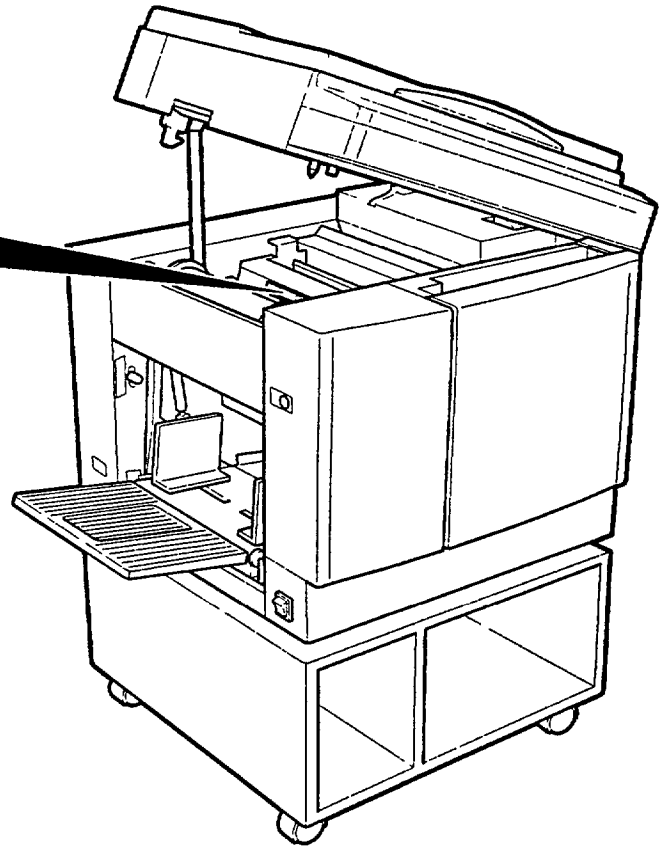

②

Warning Never touch the drum or rollers when operating the Drum Rotator Switch. Never put your hand inside this unit when it is in operation. Fingers caught between the drum and/or rollers could be pulled into the unit, resulting in injury.

J3/T 13210

No.	Parts No.	Name	Q'ty
①	J3-T3200	Warning Sticker 1	1
②	J3-T3210	Warning Sticker 1	1

Positioning the Machine

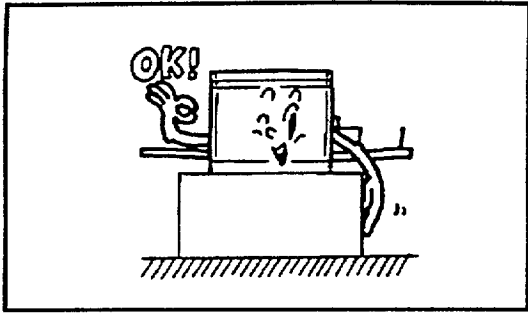

Installing the machine on a flat, stable surface.

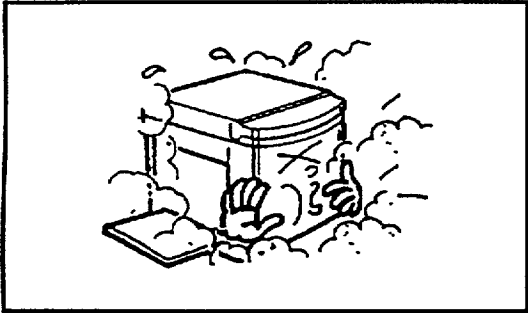

Avoid installing the machine in a dusty area.

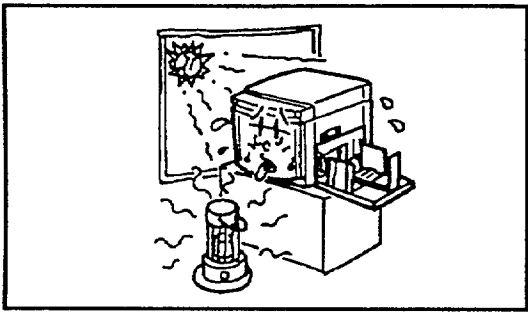

Avoid installing the machine in the direct sunlight or heat, such as near a stove. Ink may deteriorate and may cause bad prints, while the machine may indicate errors due to overheating caused by sunlight. Also avoid hot, cold, or humid areas since paper may absorb moisture, causing paper jams or wrinkles.

Cautions

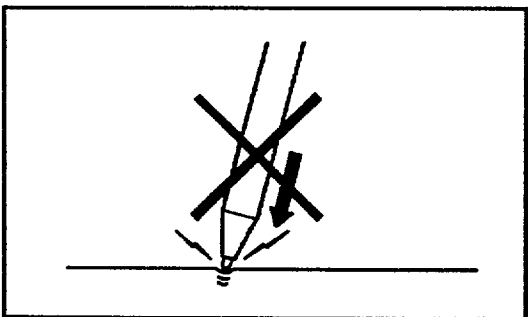

Do not apply undue pressure to the LCD Panel.

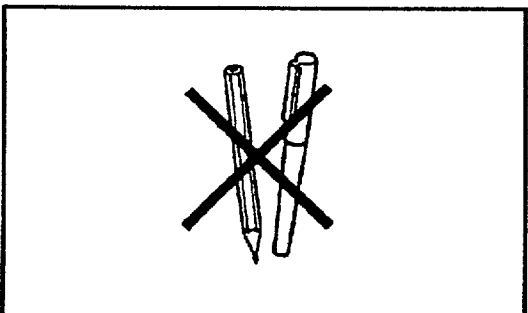

Do not use writing instruments other than the input pen that comes with the printer.

Maintenance



Clean the exterior of the machine as described below.

Tightly wring a soft cloth that has been moistened with water or neutral detergent, and wipe dirt from the machine's surface.

Never use alcohol or organic solvents. Doing so may discolor or damage the machine exterior.

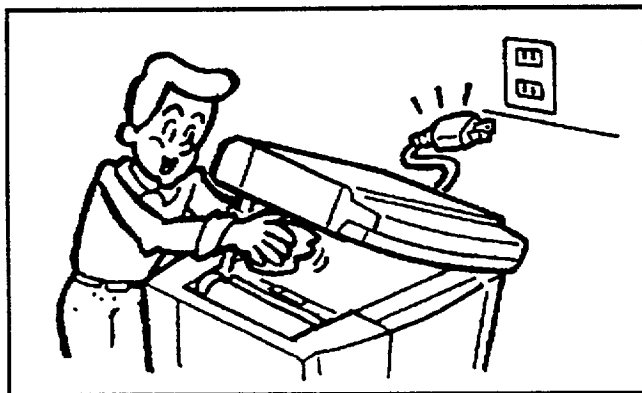

Dust and clean the machine at least once a week to avoid breakdowns. Before cleaning, turn the power switch OFF, and then remove the power plug from the outlet

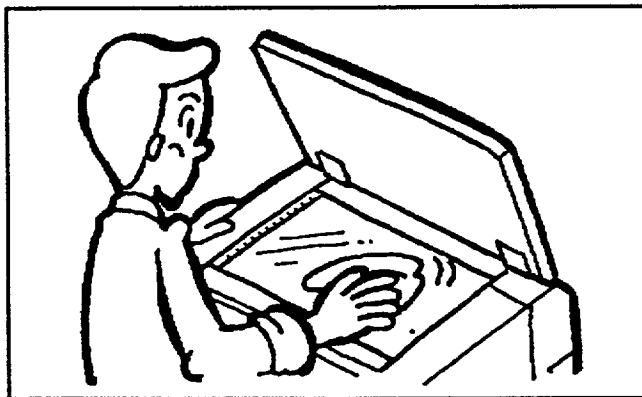

To clean the reader glass, use a dry, soft cloth and lightly wipe off any dirt.



WARNING

- Before cleaning, remove the power plug from the outlet. Doing so may result in fire or electric shock.
- Prevent water and neutral cleansers from getting inside the machine. If liquids spill inside the machine, contact your agent immediately. Using the machine with water spilled inside may result in fire or electric shock.

Printing and Duplicating Cautions

There are restrictions on what you may print on this printer. Please be aware that there are some printed materials that are illegal even to possess.

1. Printed Matter Banned by Law

- Paper money, currency, government bonds and national and local bonds cannot be duplicated, even if they are stamped with the “sample” seal.
- Paper money, currency and bonds, etc that are valid in a foreign country cannot be duplicated.
- Unused postage stamps and postcards cannot be duplicated without government consent.
- Government-issued papers pertaining to stamps, liquor and sales tax laws cannot be duplicated.

2. Printed Matter that Require Caution

- Printed-issued securities (stocks, bills and checks, etc.), passes and tickets require caution in duplicating unless a business is duplicating them for required number for their own business needs.
- Government-issued passports, public- and private-issued driver’s licenses, permits, IDs, passes, food stamps, etc. require caution in duplicating.

3. Copyrighted Materials

Books, music, artwork, prints, maps, diagrams, movies, photography, etc. are banned from duplicating outside the limits of private home use and their related non-sale usage.

Document/Copy paper Specification

Acceptable Documents

- Weight: Sheet documents, books, etc. not exceeding 2 kg.
- Size: Max. 297mm × 432 mm

Acceptable Copy paper

- Copy paper thickness: 53 g/m² to 210 g/m²
- Copy paper size: Max. 297mm × 432 mm
Min. 100mm × 150 mm
- Stacking capacity: Paper tray: 1000 sheets (55 kg top-grade paper)
Stacker: 1000 sheets (55 kg top-grade paper)

IMPORTANT

The following types of paper cannot be used:

- Paper with large file—binding holes
- Paper with staples or paper clips attached
- Paper with smaller pieces of glued paper
- Carbon-backed paper
- Paper with markedly curling ends/sides, or marked folds

Tip

Set the platemaking range according to the selected paper size.

Reference

For details on the paper size, see Chapter 2, “Selecting the Paper Size.”

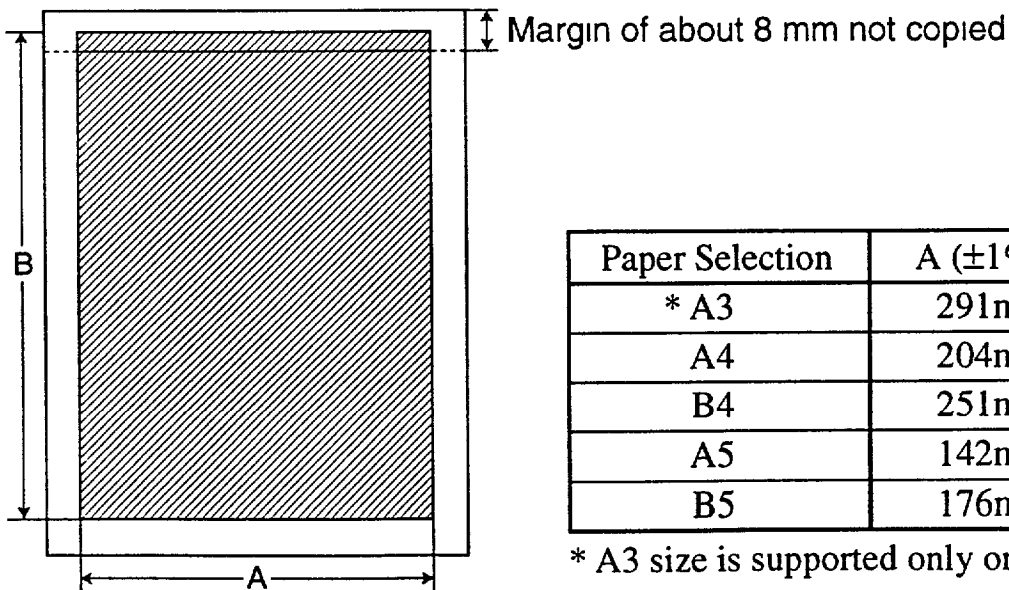

Paper Selection	A (±1%) × B (±1%)
* A3	291mm 414mm
A4	204mm 291mm
B4	251mm 358mm
A5	142mm 204mm
B5	176mm 251mm

* A3 size is supported only on the DP-43E.

System Setup

The machine and its optional equipment are set up as follows:

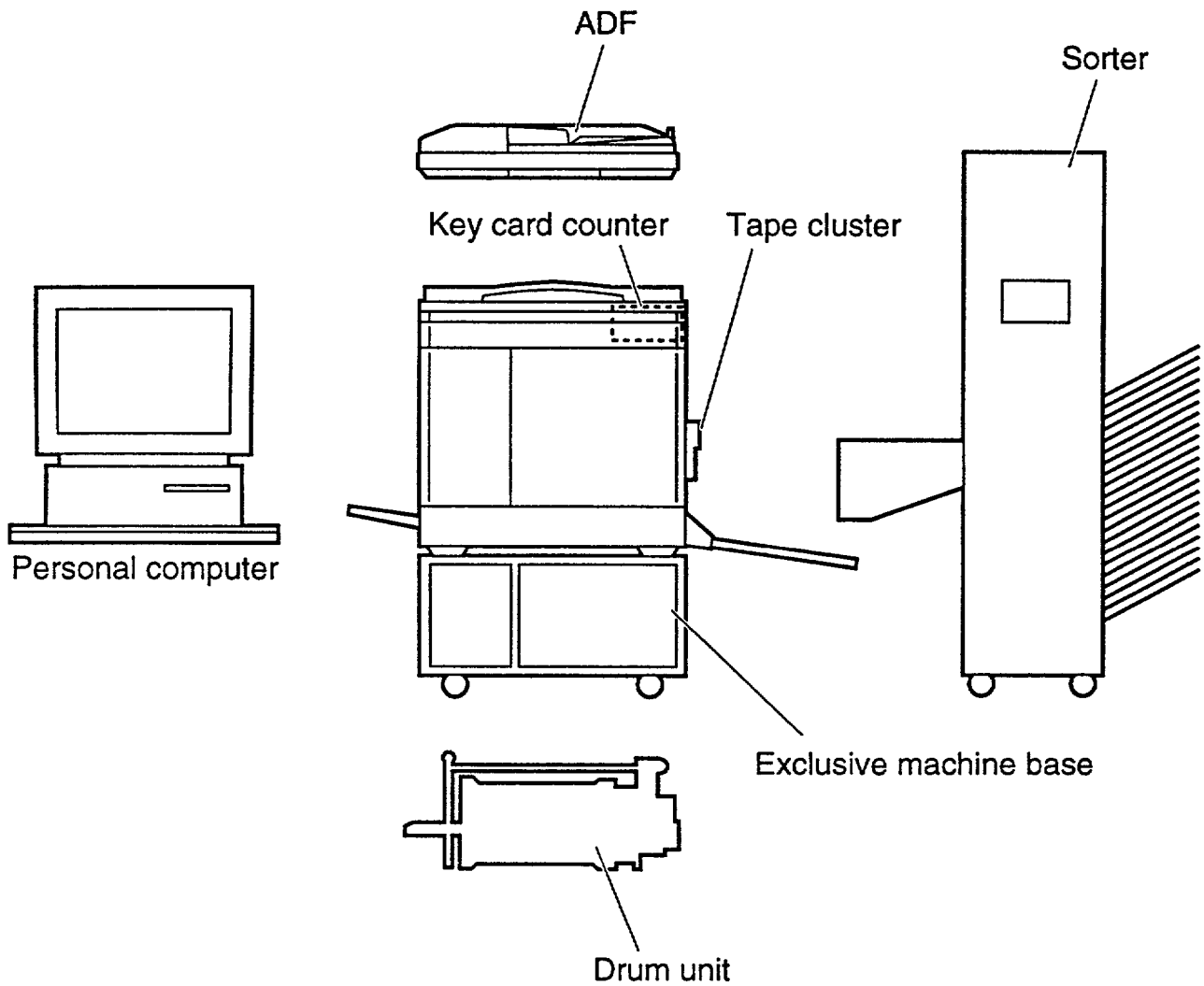

Documents prepared on a personal computer can be printed on this machine. The IPC board and PC interface kit are required to connect this machine to a personal computer.

Part Names and Their Functions

Machine exteriors

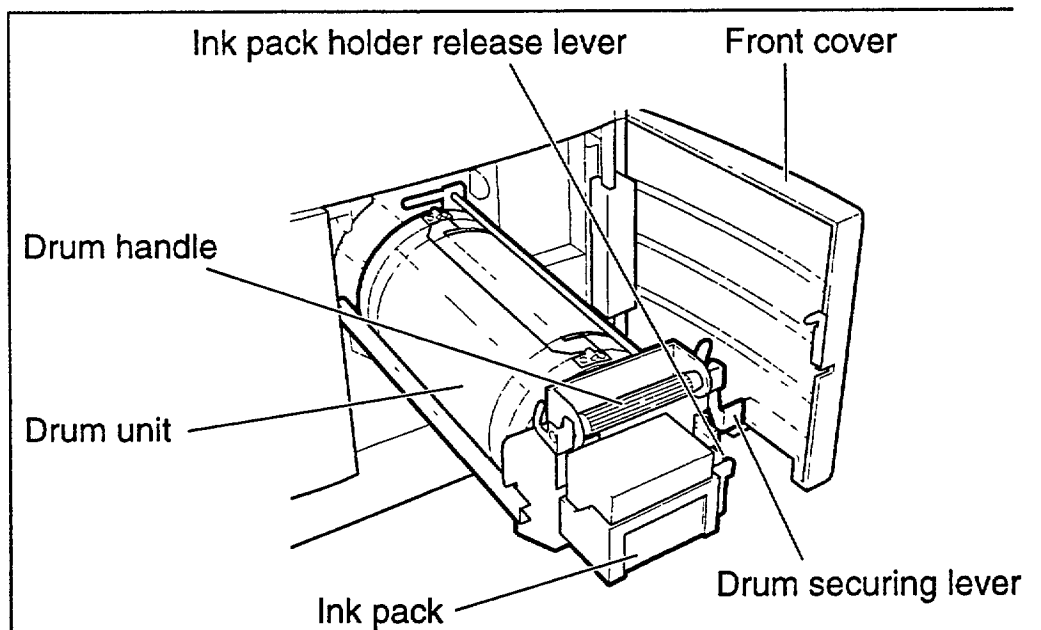
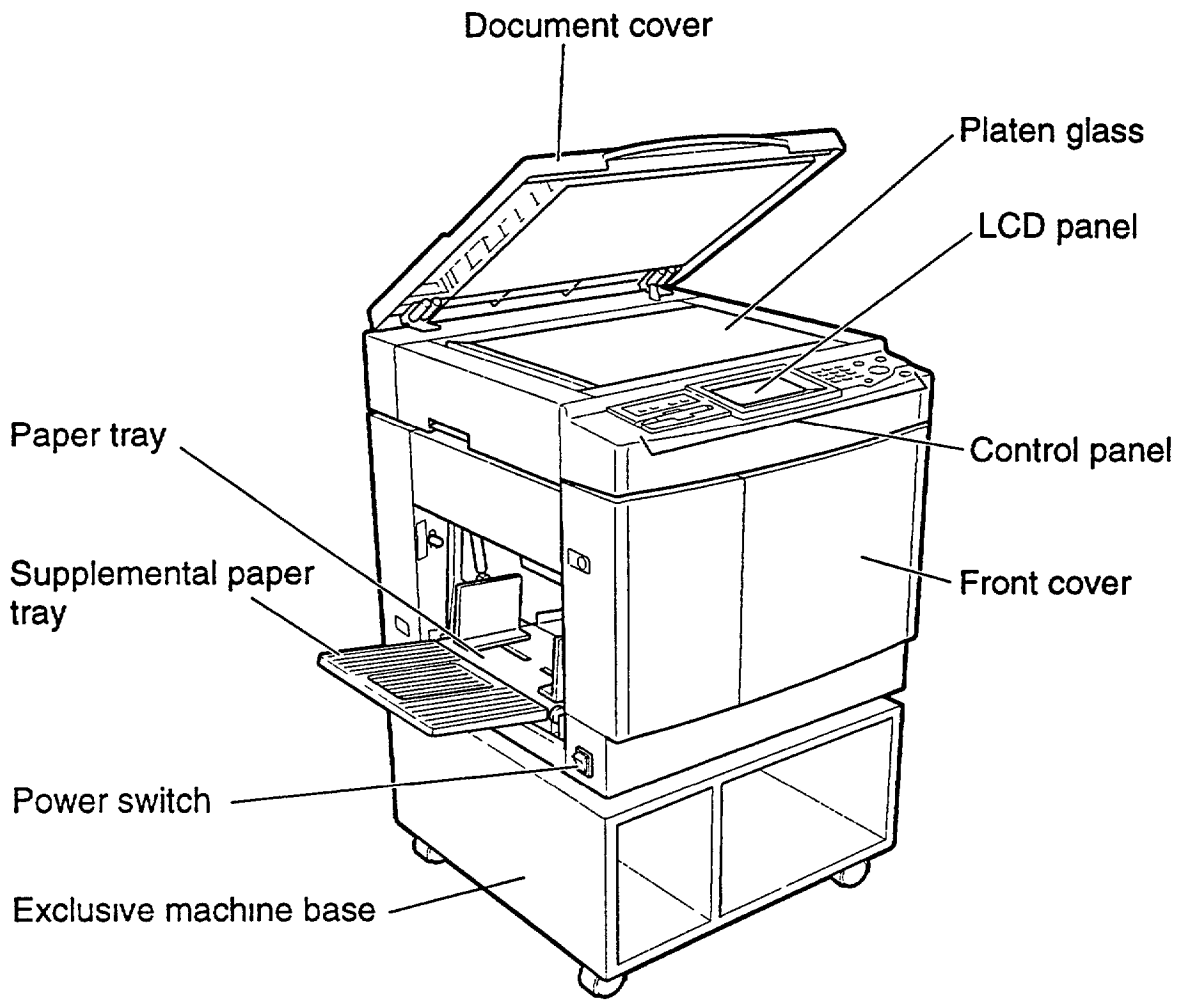

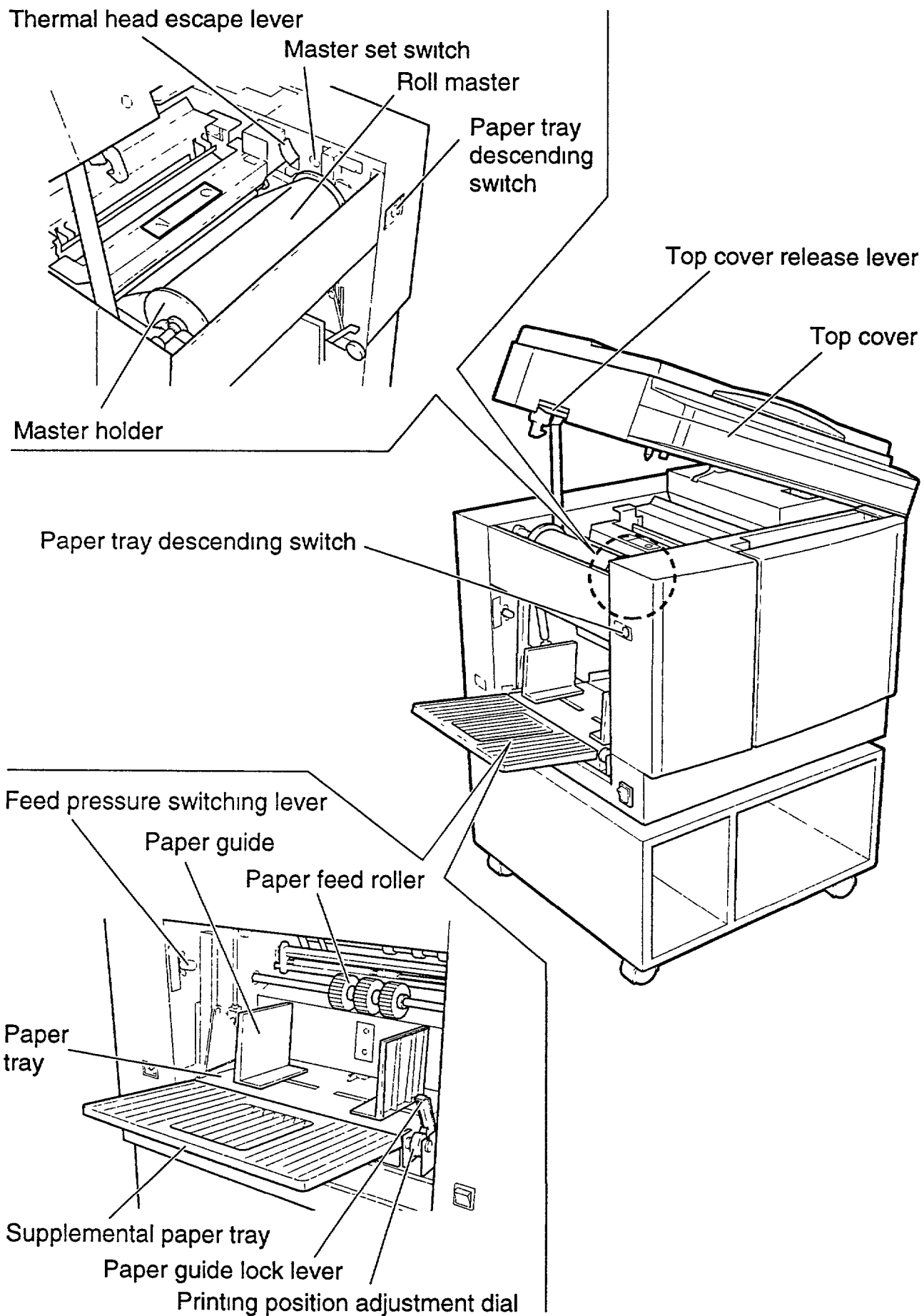

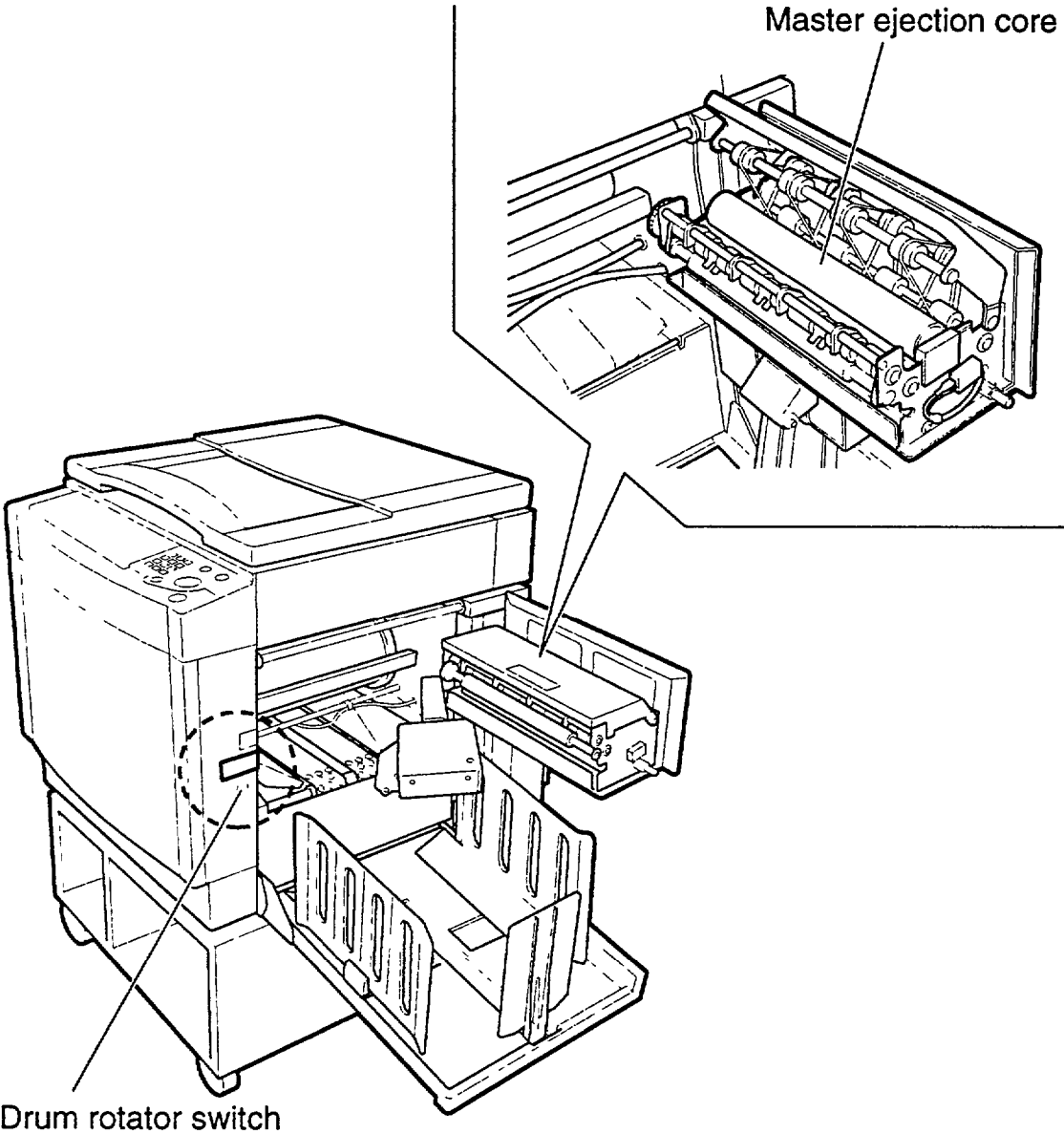

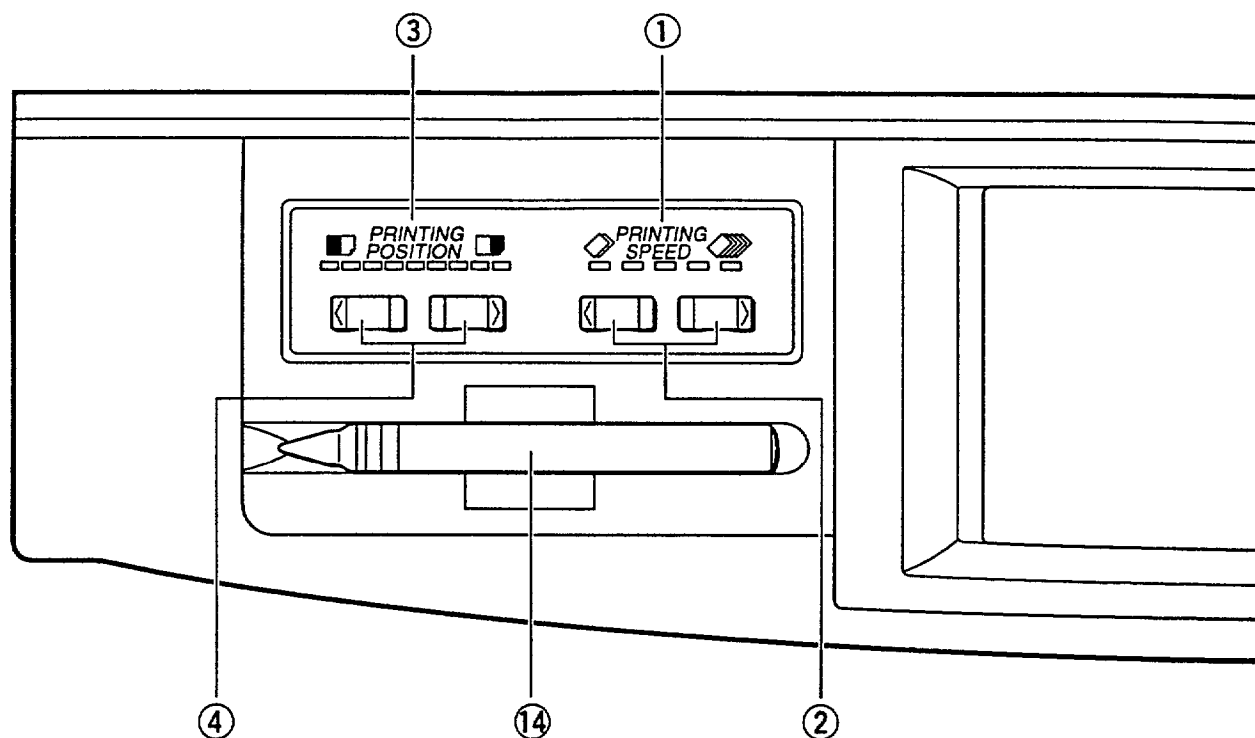

No.	Components	Functions
①	Printing speed indicator lamp	The lamp for the specified printing speed lights
②	“PRINTING SPEED ADJUSTMENT” keys	The printing speed is adjusted with these keys
③	Printing position indicator lamp	The lamp for the specified printing position lights.
④	“PRINTING POSITION ADJUSTMENT” keys	The printing position (vertical) is adjusted with these keys.
⑤	“PLATEMAKING” key	Starts platemaking.
⑥	“TEST PRINT” key	Prints one copy. This is used to check the image position and contrast
⑦	“PRINT” key	Starts printing. This will not start platemaking. When the tape cluster or ADF have been installed, platemaking will start automatically after end of printing if the document is placed on the ADF.
⑧	“STOP” key	Stops printing. If this key is pressed while the machine is stopped, the number of copies and plates will be displayed.
⑨	“ALL CLEAR” key	Returns the control panel settings back to the standard made. Hold down for at least 0.5 second
⑩	LCD panel	Displays number of prints and other machine settings. Displays error messages when error is occurred.
⑪	Key pad	Used for entering the number of prints.
⑫	“CLEAR” key	Clears the display to “0”. Clears the number of prints only.
⑬	⊗ key	Enters the number of prints and number of sets. To enter the number of prints per document after a clear, press the ⊗ key
⑭	Input Pen	Used with the Edit Functions.

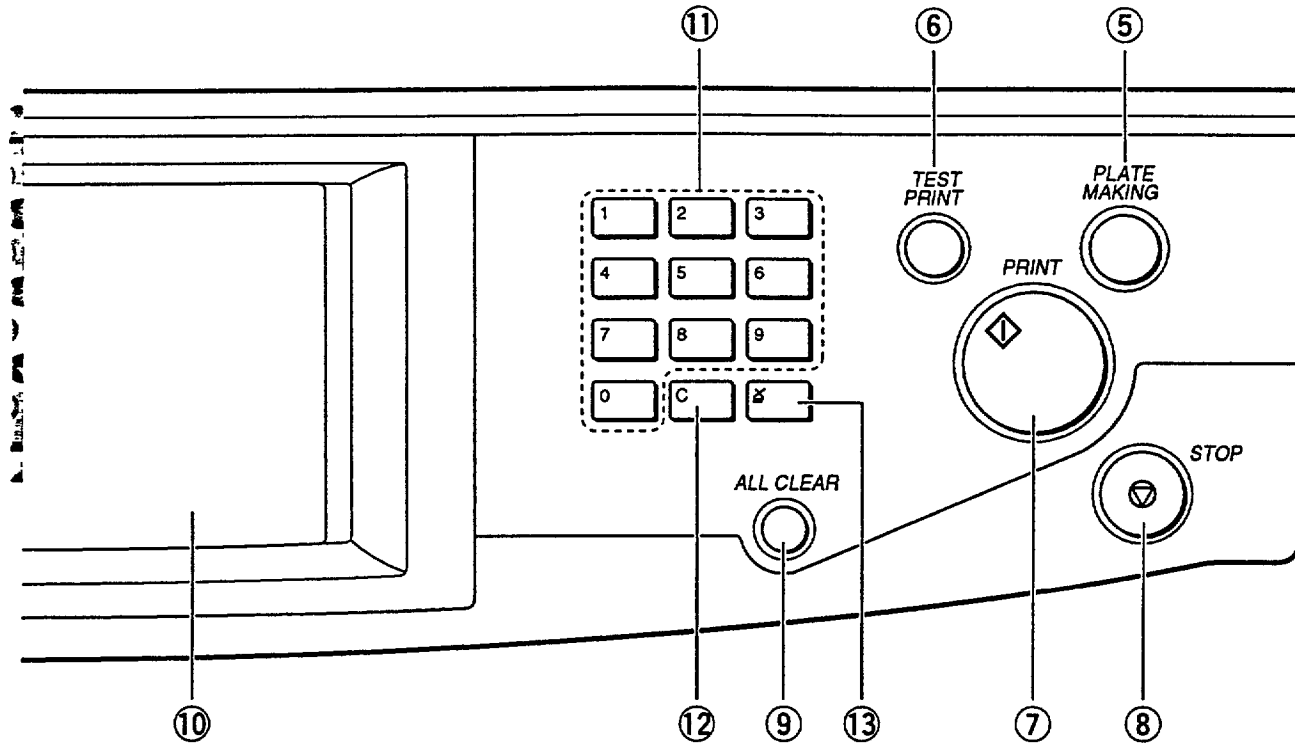

LCD Panel Main Screen

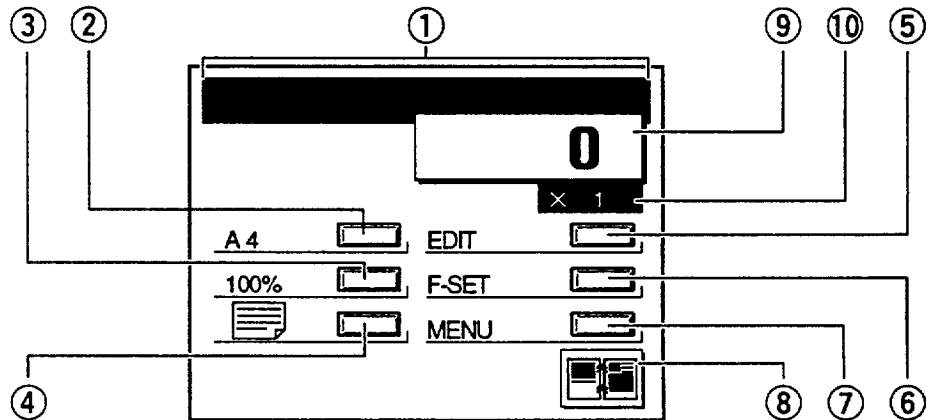

No.	Components	Functions
①	Message Display Area	Displays "PRINT" and other messages related to the operation of the printer.
②	Paper Size	This button is used to select the size of the paper for printing
③	Enlargement/Reduction	This button is used to set the enlargement/reduction ratio.
④	Photograph Mode	This button is used to set the Photograph Mode and other Platemaking methods.
⑤	Edit	This button is used to select Editing Functions.
⑥	F Settings	This button is used to select Function modes.
⑦	Menu	This button is used to display and manipulate the Menu Screen.
⑧	Status	This button displays the current settings.
⑨	Counter	Displays the number of copies remaining to be printed.
⑩	Number of Sets	Displays the number of sets.

How Platemaking and Printing is Carried Out

The machine carries out the processes of “platemaking” and “printing.”

Platemaking

In the “platemaking” process, the old master on the drum is removed while the thermal head creates the scanned image on the new master and transfers it onto the drum.

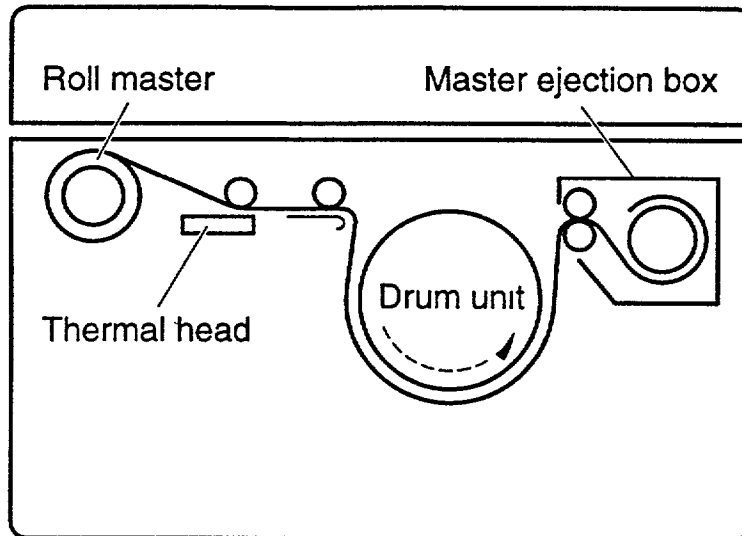

Printing

In the “printing” process, paper separated from the stack by the feeder ring and the paper separator unit is pressed against the drum unit by the press roller. There are small holes over only the image area of the master that is attached to the drum, and ink that seeps from these holes is transferred to the paper. The paper is then peeled from the master by the paper stripper finger and the top blow fan. The paper is directed onto the paper ejection belt by a fan unit and discharged from the machine.

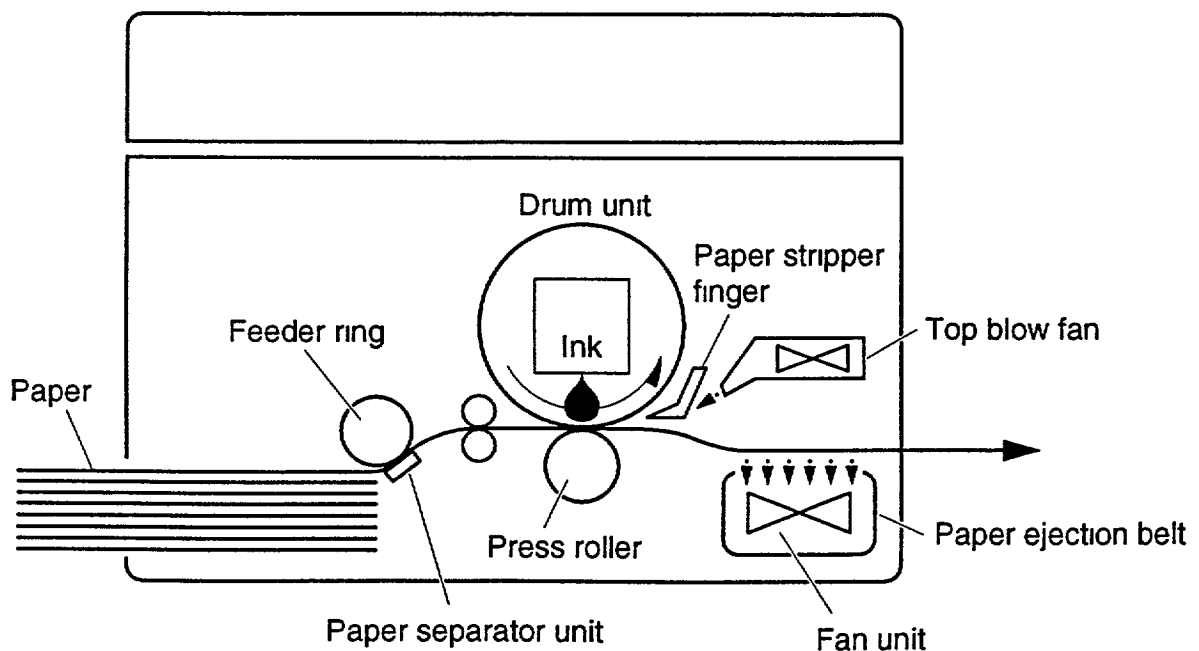

2. Platemaking and Printing Procedure

Preparations

Placing the Paper

1 Open the supplemental paper tray if it is closed.

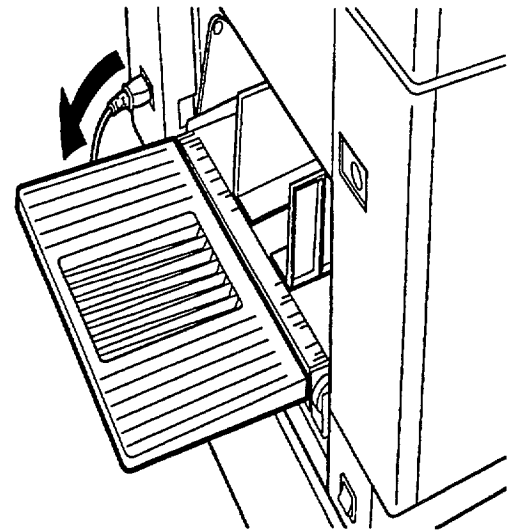

2 Raise the paper guide lock lever to manually move the paper guides.

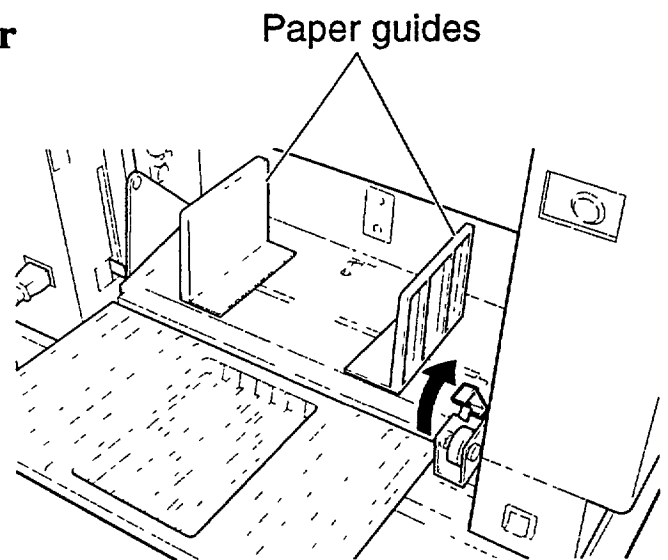

3 Set the paper guides to the size of the paper to be used.

4 Load a stack of aligned sheets between the paper guides and press the stack lightly toward the machine.

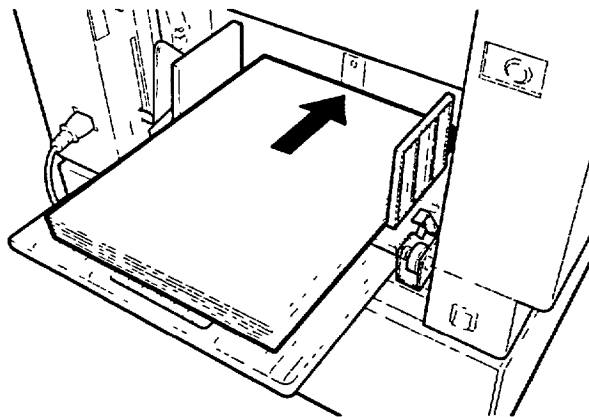

5 Lower the paper guide lock lever to lock the paper guides in place.

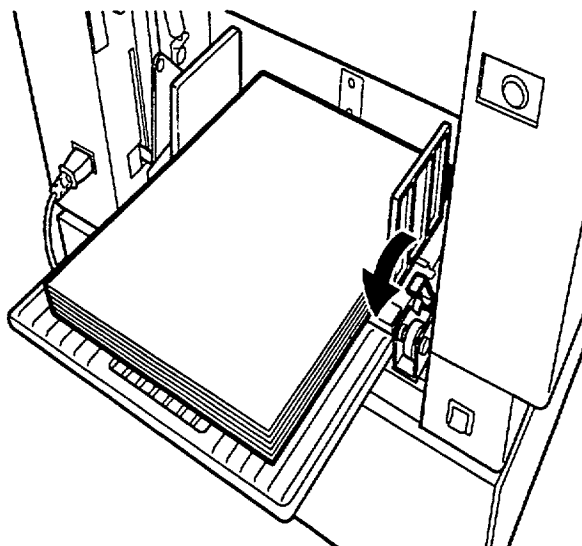

Setting the Paper Stacker

1 Open out the paper stacker.

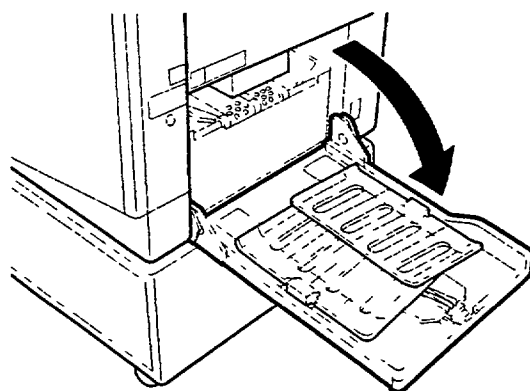

2 Open out the paper stacker guides.

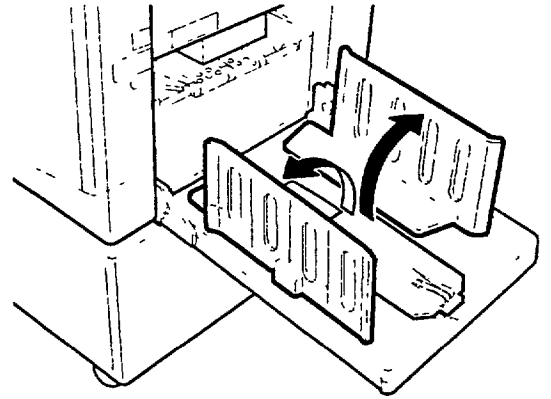

3 Open out the paper stopper.

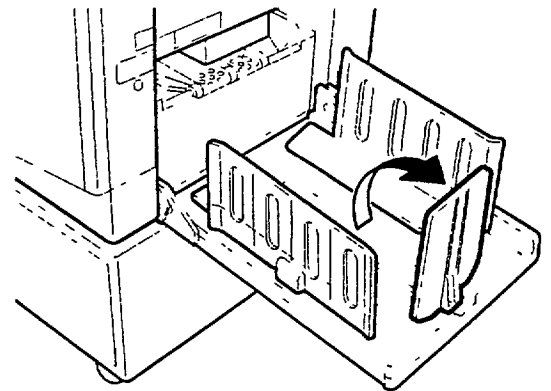

4 Adjust the paper stacker guides and paper stopper to the size of the printing paper.

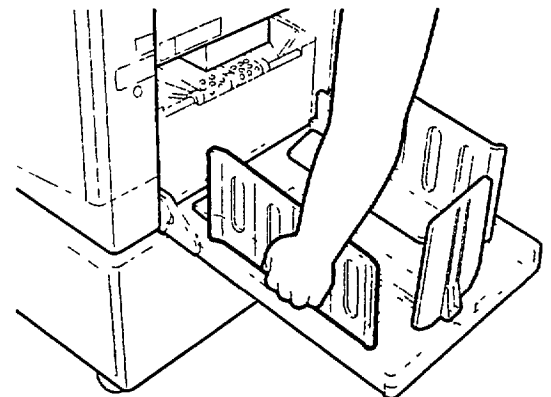

Turning the power ON

- 1 The machine is ON when the power switch is turned to the “|” side.

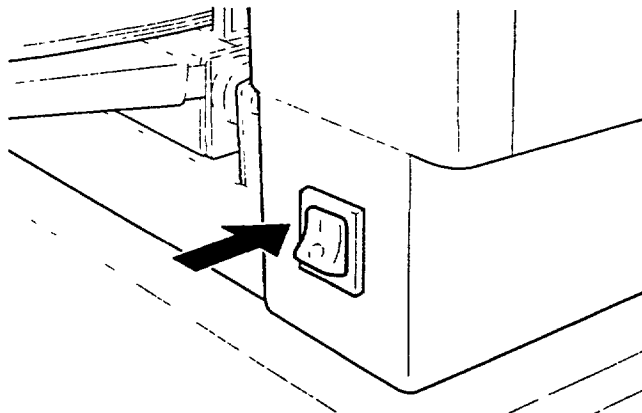

Platemaking

Checking the Control Panel

- 1 The indicator lamps on the control panel will light and the machine will be ready for platemaking and printing.

The display on the control panel indicates the standard mode. This is the Main Screen.

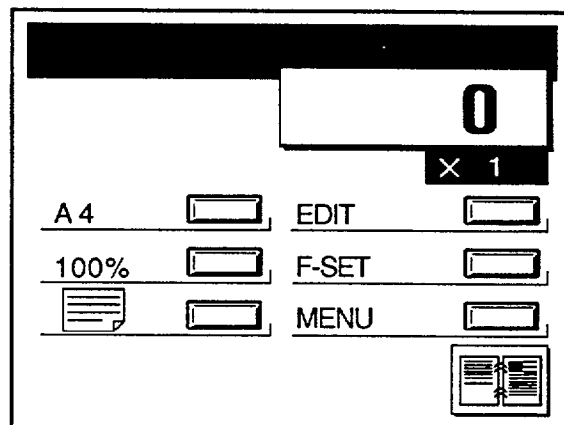

To change the standard mode settings, see Chapter 3, “Special Functions.”

IMPORTANT

When the message “PLEASE INSERT CARD” is displayed, insert the card into the key card counter. (only when the key card counter is attached)

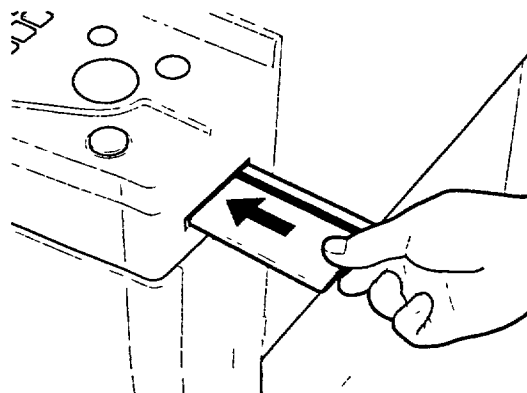

Placing the Document

1 Open the document cover gently.

2 Match the document size along the scale.

3 Close the document cover gently.

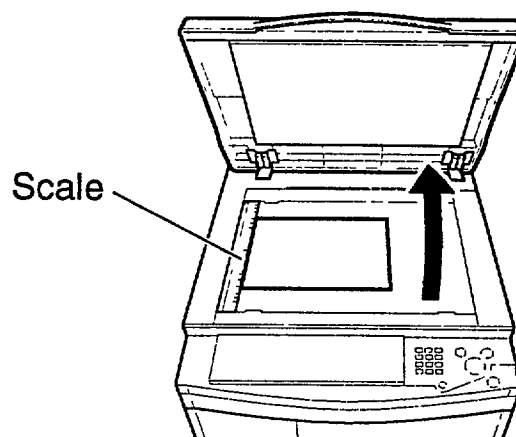

Mode setting

Set the mode if platemaking is to be carried out in a different mode from the standard mode.

Change the following settings before platemaking since they are not effective when changed after platemaking:

Tip

- Text/photograph mode
- Paper size selection
- X 94%
- Zoom factor (including auto zoom, zoom)
- Fine text/screen mode
- Multiple printing
- Dark photo

Selecting the Paper Size

1 Make sure the Main Screen is displayed.

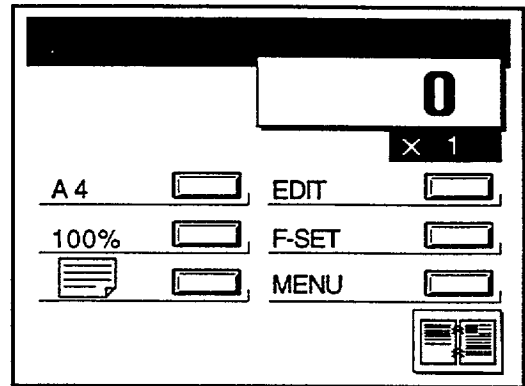

2 Press the [Paper Size] key.

IMPORTANT

- The paper sizes available are displayed on the Main Screen.
- Paper sizes other than [A4] are also displayed.

3 Select the paper size you want to use for printing.

Paper size selection is based on lateral placement of document. When the document is placed vertically, select one size larger.

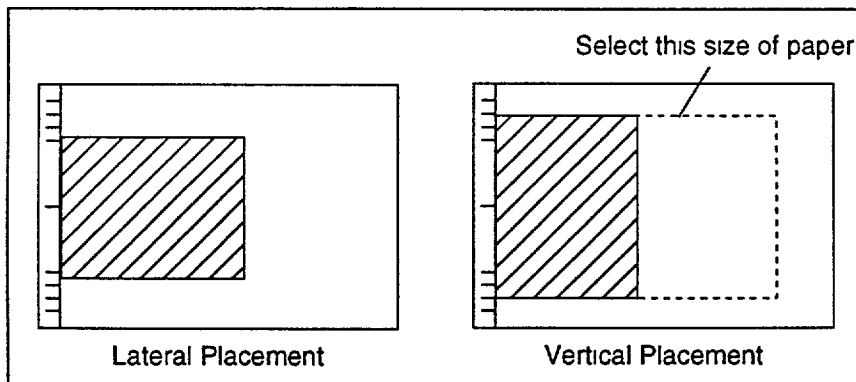
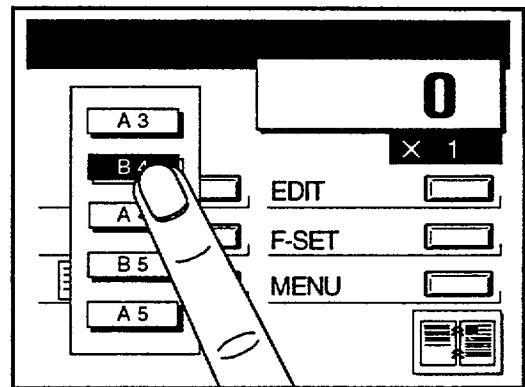

After a while, the paper size is displayed and the display returns to the Main Screen. The paper size set via the selection operation is displayed on the Main Screen.

IMPORTANT

- When you make plates without selecting the paper size, and print on smaller size paper, the inside of the machine or prints may become dirty.
- Layout will not be correct in multiple printing, if you select wrong size.

Platemaking

1 Press the “**PLATEMAKING**” key.
Only one print will be made after platemaking.

2 Check the finished plate.
Check the printing position, density and other factors that affect the finish.

Making Prints

1 Enter the number of prints on the key pad.



To change the number of prints, press the “**CLEAR**” key, and enter the desired number of prints.

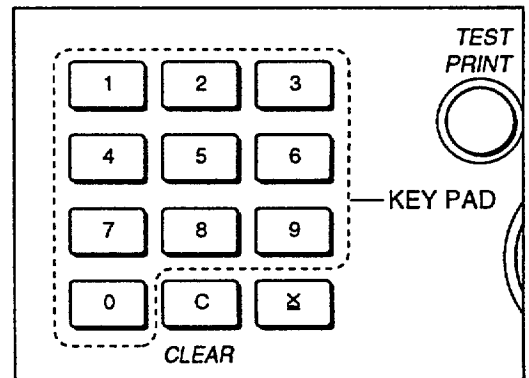

2 Press the “**PRINT**” key.
Printing will start and the counter will count down the number one by one.



If you want to stop the machine midway during operation, press the “**STOP**” key. To resume printing, press the “**PRINT**” key again.

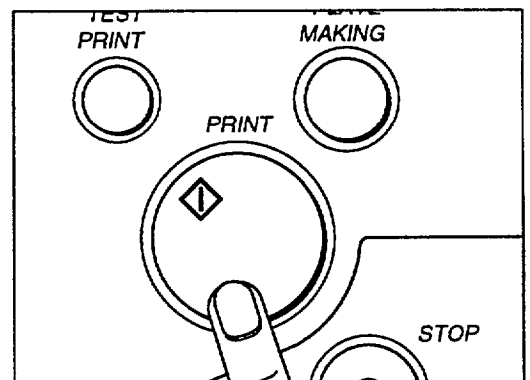

3. Various Functions

DISPLAYING THE STATUS

Function

Allows you to display the current settings. The Status can be displayed even while you are in the process of selecting other settings. The items displayed are as follows:

- Number of Copies/Number of Sets
- Paper Size
- Text/Photograph Mode (Includes Text-Photograph/Fine Lettering/Halftone Dot/Dark Photo)
- Enlargement/Reduction Ratio (Includes $\times 94\%$)
- Print Contrast (Darker/Lighter)
- [Plate Contrast (Darker/Lighter)
- Makeup ON/OFF
- Trimming ON/OFF
- Book Shadow Eraser
- Multiple Printing
- Sort Mode

Operation

1 Select  on the LCD Panel.

Current settings are displayed.

 For more information on how to read the LCD Panel, see the Section "Function Mode Screens and Their Features" in Chapter 4.

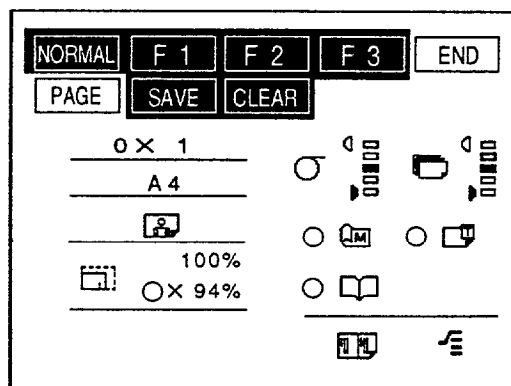

Test Printing

Function

Makes a single print to check the finished plate.

Operation

1 Press the "TEST PRINT" key.

Only one print is made.

2 Check the image on the test print and adjust and change the printing mode if necessary.

IMPORTANT

- Make another plate if you changed the following settings:
 - Text/photograph mode
 - Paper size selection
 - X94%
 - Zoom factor (including auto zoom, zoom)
 - Fine text/screen mode
 - Multiple printing
 - Dark photo
 - Edit Settings

Adjusting the Platemaking Density (darkness)

Function

The platemaking density (contrast) can be adjusted in five steps. Adjust the platemaking density to a darker setting for light-colored documents, and to a lighter setting for dark-colored documents.

IMPORTANT

- Adjust the platemaking density before starting platemaking.

III Operation

1 Make sure the Main Screen is displayed.

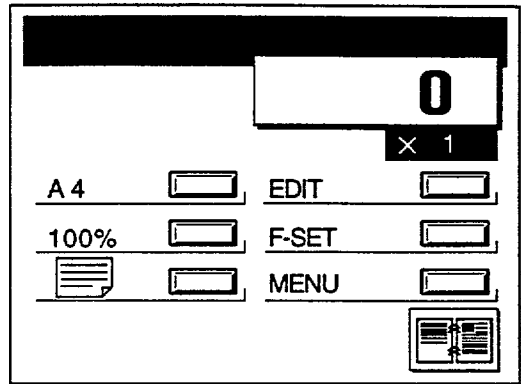

2 Select [MENU].

The Menu Screen is displayed.

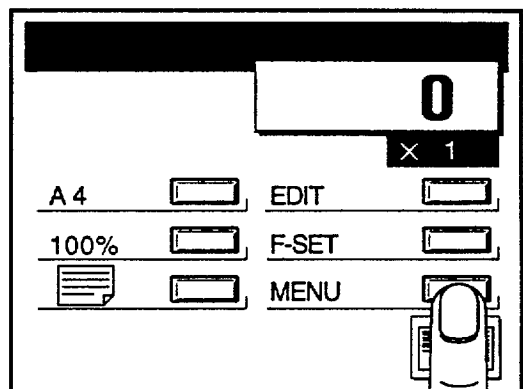

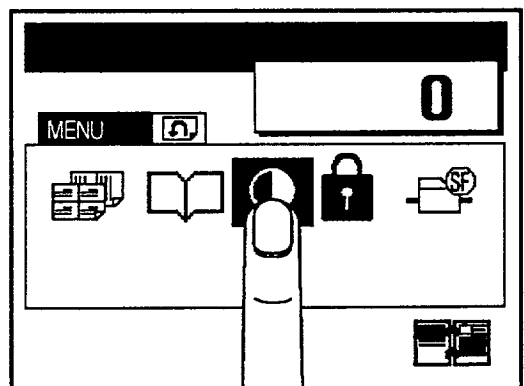

3 Select .

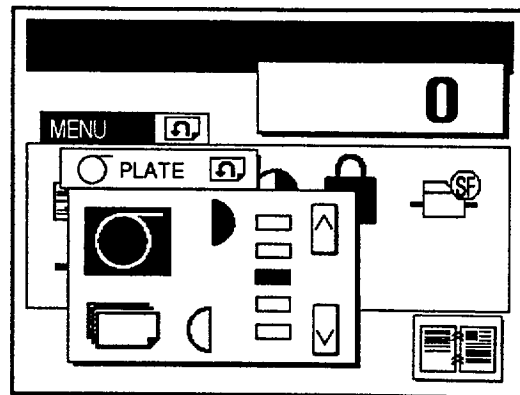

4 Select the Plate Contrast  icon.



5 Adjust the darkness by pressing the   keys.

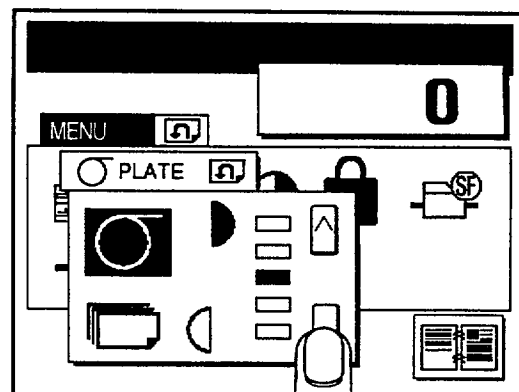

6 Press the Return  icon.

- *To return to the standard setting.
There are two ways of returning the setting to the standard setting.
- Adjust the Plate Contrast once again, setting it to [Standard].
- When the "ALL CLEAR" key is pressed, all the settings will return to their defaults.

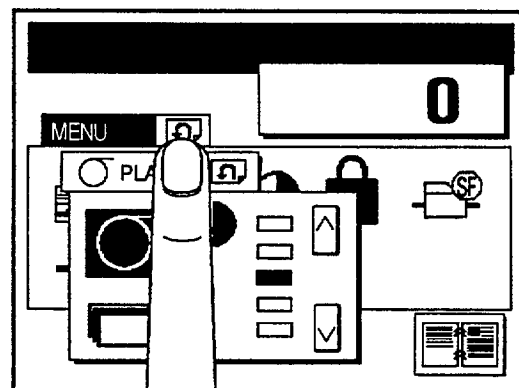

Adjusting the Print Density (ink transfer amount)

Function

The print density can be adjusted in three steps.

To increase the print density (increase the ink transfer amount), press the "DARK" key. To decrease the print density (decrease the ink transfer amount), press the "LIGHT" key.

IMPORTANT

- Make sure that the machine is not printing.
- To cancel printing midway, press the "STOP" key.

Operation

1 Make sure the Main Screen is displayed.

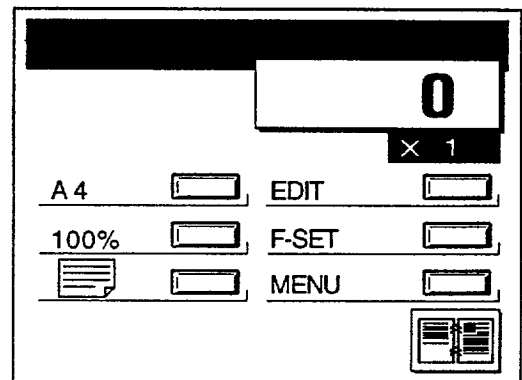

2 Select **MENU**.

The Menu Screen is displayed.

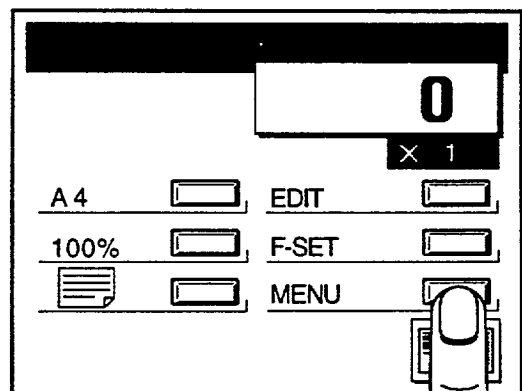

3 Select **0**.

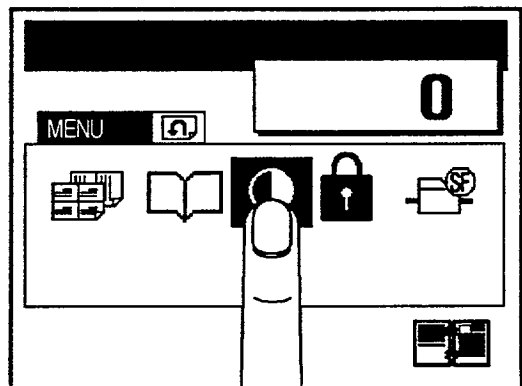

4 Select the Print Contrast icon.

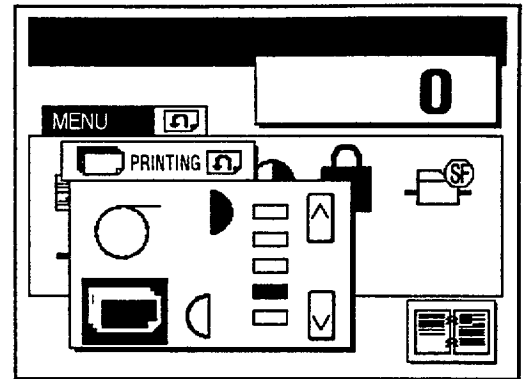

5 Adjust the darkness by pressing the keys.

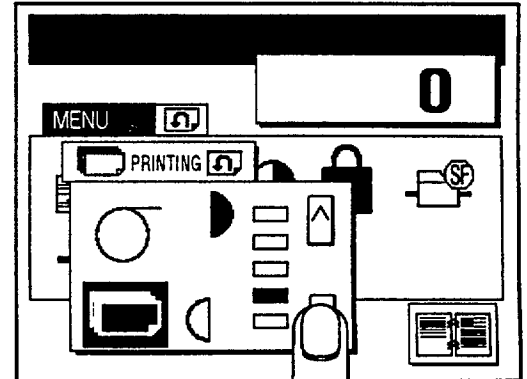

6 Press the Return icon.

- *To return to the standard setting. There are two ways of returning the setting to the standard setting.
 - Adjust the Print Contrast once again, setting it to [Standard].
 - When the "ALL CLEAR" key is pressed, all the settings will return to their defaults.

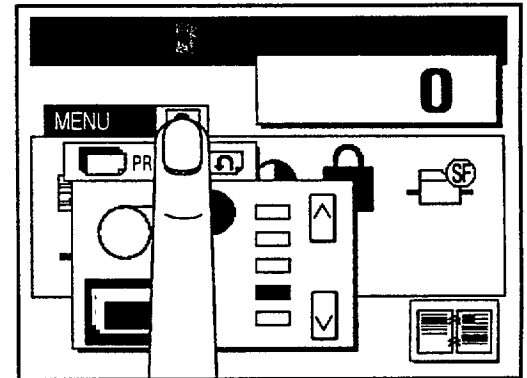



Adjusting the Printing Speed

Function

The printing speed can be adjusted in five increments from 45 sheets/minute to 120 sheets/minute. The default setting is approximately 80 sheets/minute. The speed can be increased or decreased by [FAST] or [SLOW], respectively, to find the more appropriate printing speed. You can change the printing speed during printing.

III Operation



1 Press the  or  key to adjust the machine to an appropriate speed.

Pressing the  key moves the printing speed indicator lamp to the left, and decreases the printing speed.

Pressing the  key moves the printing speed indicator lamp to the right, and increases the printing speed.

*To return to the standard setting

There are two ways of returning the setting to the standard setting.

- Press the  or the  to move the printing speed indicator lamp to the center position.
- When the "ALL CLEAR" key is pressed, all control panel indicators will return to their defaults.

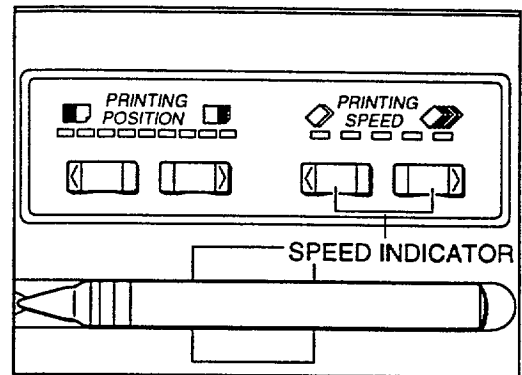



Adjusting the Printing Position (vertical)

III Function

After platemaking has finished, you can fine-tune the position of the image (in the vertical direction) within ± 1.5 cm. The multiple printing indicator lamp will move one notch with approximately every 3 mm of movement. You can change the position during printing.

III Operation

1 Press the  or  "PRINTING POSITION ADJUSTMENT" keys to adjust the printing position.

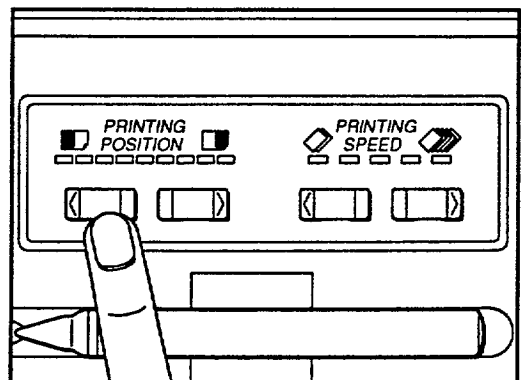

To move the printing position to the feed side, press the  key. The printing position indicator lamp moves to the left.

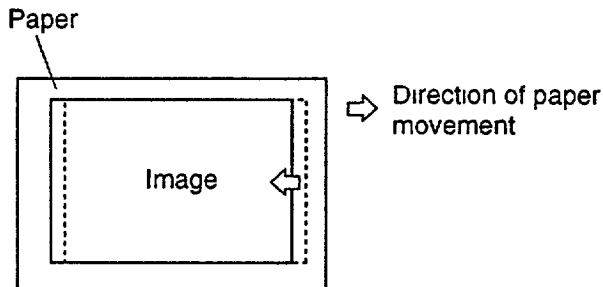

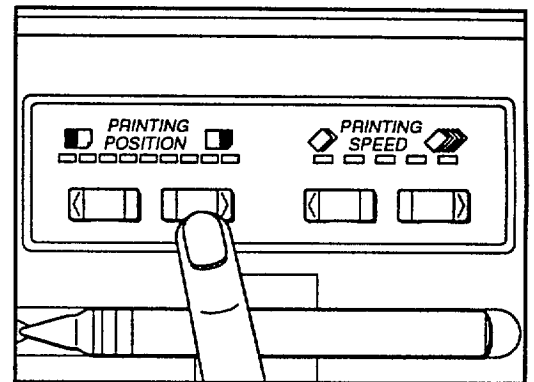
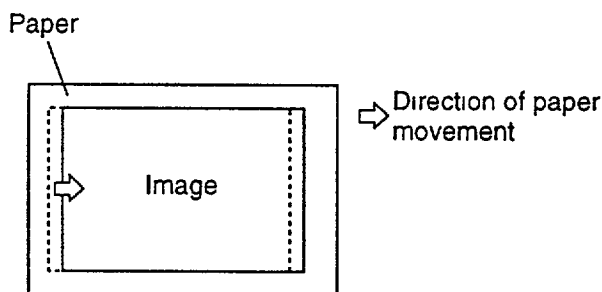

To move the printing position to the ejection side, press the  key. The printing position indicator lamp moves to the right.



*To return to the standard setting

There are two ways of returning the setting to the standard setting.

- Press the  or the  to move the printing position indicator lamp to the center position.
- When the "ALL CLEAR" key is pressed, all control panel indicators will return to their defaults.

Adjusting the Printing Position (horizontal)

Function

After platemaking has finished, you can fine-tune the printing position (horizontal) within ± 1 cm.

Operation

IMPORTANT

- Make sure that the machine is not printing.
- To cancel printing midway, press the "STOP" key.

1 Slightly press the paper tray descending switch to release the paper from the feeder ring.

Paper tray descending switch

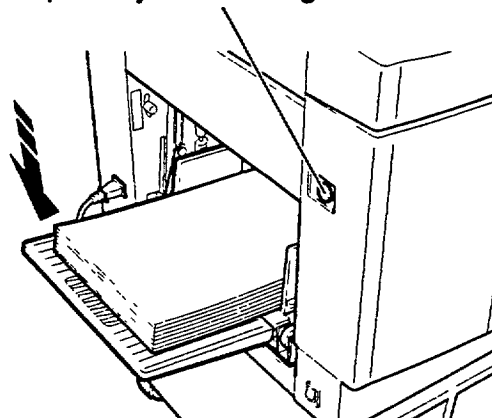

2 Adjust the printing position with printing position adjustment dial.

To move the printing position to the right (control panel side), rotate the dial towards you. The paper tray moves to the left (opposite side of control panel).

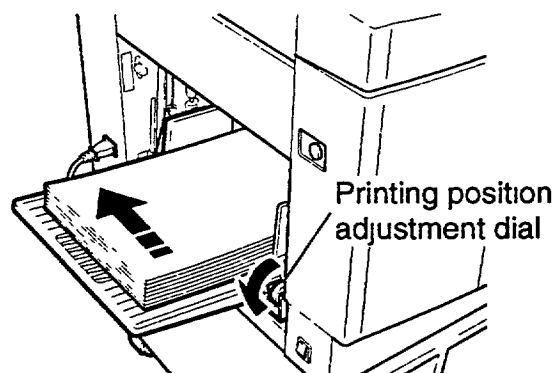

Printing position adjustment dial

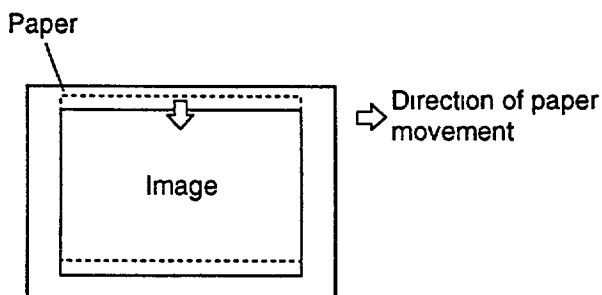

Adjusting the Printing Position (horizontal)

To move the printing position to the left (opposite side of control panel), rotate the dial away from you. The paper tray moves to the left (control panel side).

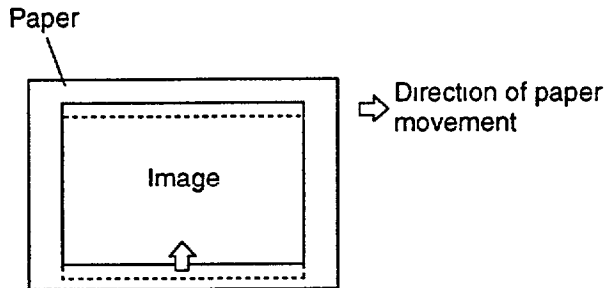
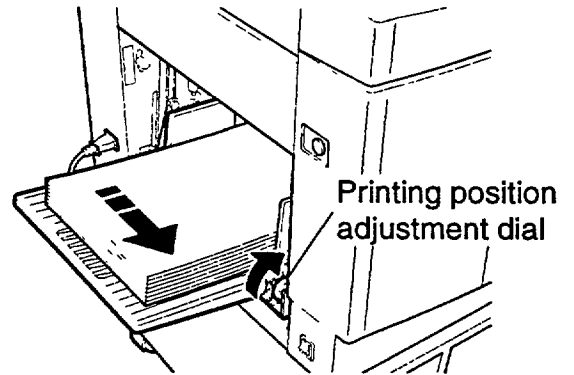

***To return the standard setting**
Turn the dial and align with the center of the paper tray scale.

Using a Thick or Thin Paper (adjusting the feed pressure)

Function

The feed pressure can be adjusted.

Adjust the feed pressure if you encounter a feed error when printing on thick or thin paper.

IMPORTANT

- When printing has ended, return the feed pressure switching lever to "NORMAL" for the next person.

Operation

IMPORTANT

- Make sure that the machine is not printing.
- To cancel printing midway, press the "STOP" key.

1 Adjust the feed pressure switching lever.

When using thick paper (or the paper slips and is not fed), set the feed pressure switching lever to "HEAVY".

When using thin paper (or two sheets of paper are fed), set the feed pressure switching lever to "LIGHT".

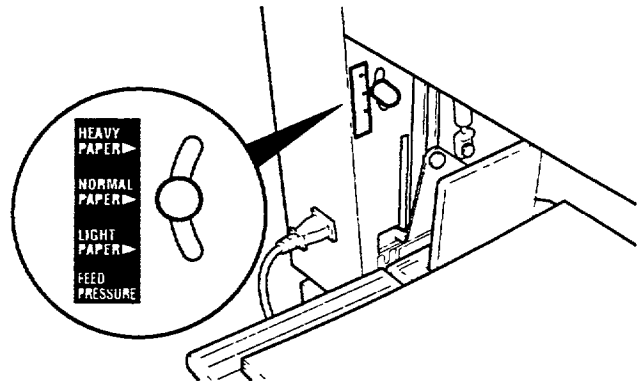

*To return to the standard setting

Set the feed pressure switching lever to "NORMAL".

Enlargement/Reduction

Enlarge/reduction (standard size → standard size)

Function

This machine is equipped with the following most commonly used enlargement/reduction percentages:

141%A4 → A3/B5→ B4

122%A4 → B4

115%B4 → A3/B5→ A4

86%A3 → B4

81%B4 → A4

70%A3 → A4/B4→ B5

IMPORTANT

- Set the zoom factor before platemaking.

Operation

- 1 Make sure the Main Screen is displayed.

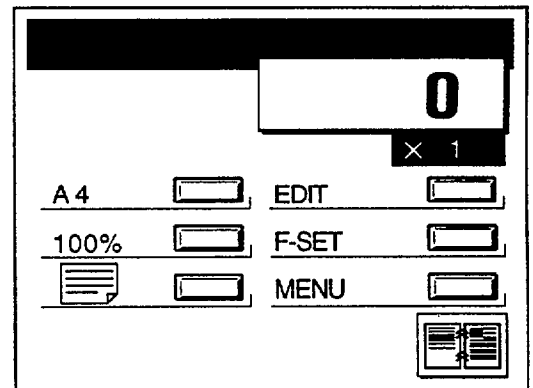

- 2 Press the [Enlargement/Reduction] key.

IMPORTANT

If the enlargement or reduction setting has already been made, that value will be displayed.

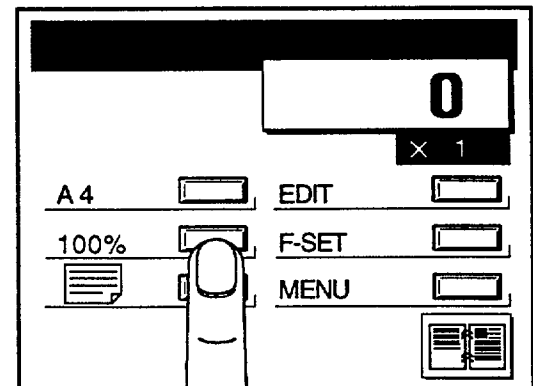

3 Select the enlargement/reduction ratio you want to set.

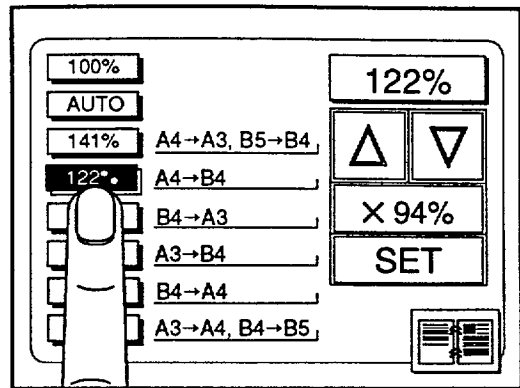

4 Select [SET].

This sets the enlargement/reduction ratio, and returns the LCD Panel to the Main Screen.

*To return to the standard setting

There are two ways of returning the setting to the standard setting.

- Reset the enlargement/reduction ratio to 100%.
- When the "ALL CLEAR" key is pressed, all the settings will return to their defaults.

Slight Reduction (94%)

III Function

The 94% reduction mode allows you to print the whole document if the edges of the document cannot be printed.

IMPORTANT

- Set to the 94% reduction mode before starting platemaking.
- The 94% reduction function cannot be used when the auto zoom function/zoom setting function is used

III Operation

1 Make sure the Main Screen is displayed.

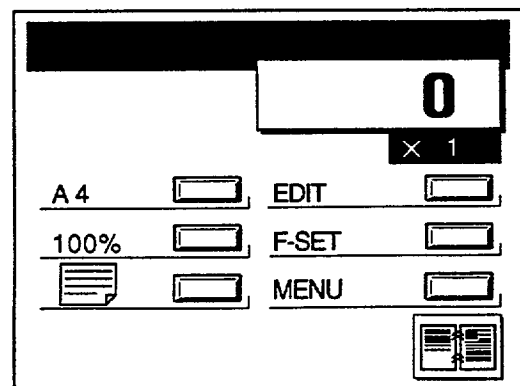

2 Press the [Enlargement/Reduction] key.

IMPORTANT
If the enlargement or reduction setting has already been made, that value will be displayed.

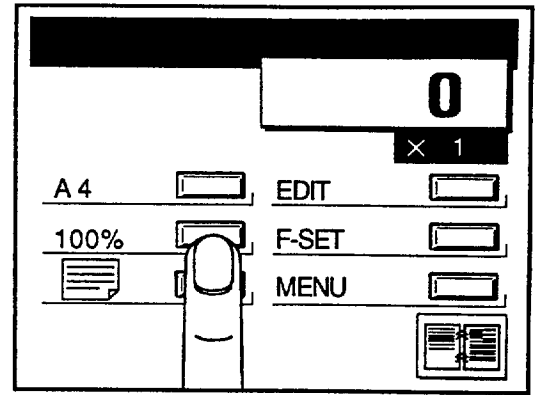

3 Select [X94%].

This displays [X94%] in reverse video, and turns the 94% Reduction Mode ON. Pressing [X94%] once again turns the 94% Reduction Mode OFF.

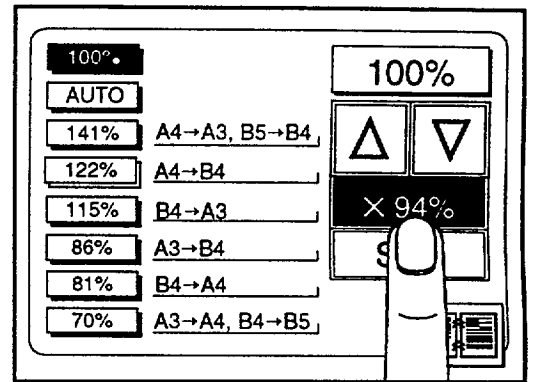

4 Select [SET].

Tip You can set the 94% reduction mode even if a size other than "100%" is selected. The zoom factor is the "X94%" zoom factor displayed on the LCD panel."

- *To return to the standard setting
- There are two ways of returning the setting to the standard setting.
- Press the [X94%] once again.
- When the "ALL CLEAR" key is pressed, all the settings will return to their defaults.

Auto Zoom Function (printing matched to the paper size)

Function

The zoom factor will be set automatically. All you have to do is to set the document in place and select the paper size.

IMPORTANT

The 94% reduction function cannot be used when the auto zoom function is used.

Operation

- 1 Make sure the Main Screen is displayed.

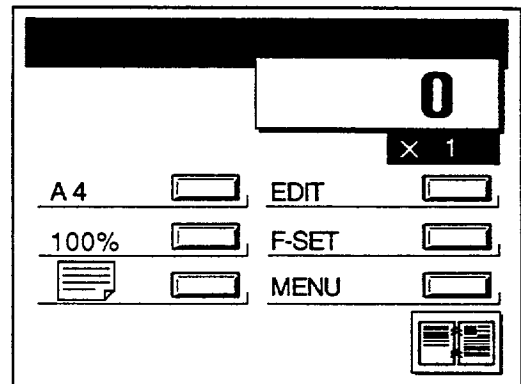

- 2 Press the [Enlargement/Reduction] key.

IMPORTANT

If the enlargement or reduction setting has already been made, that value will be key.

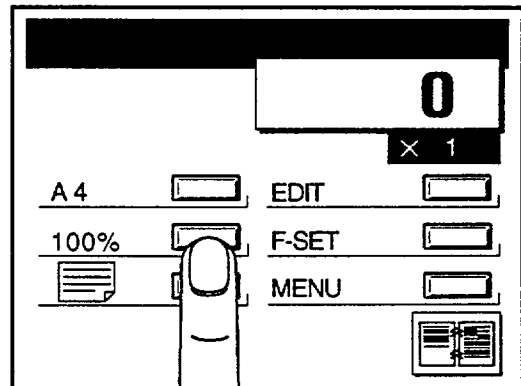

- 3 Select [AUTO].

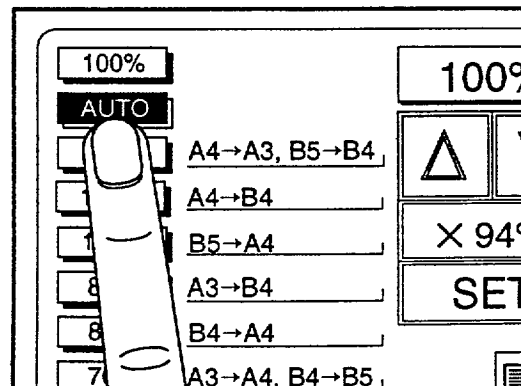

4 Press [SET].

This sets Auto Zoom and returns the LCD Panel to the Main Screen.

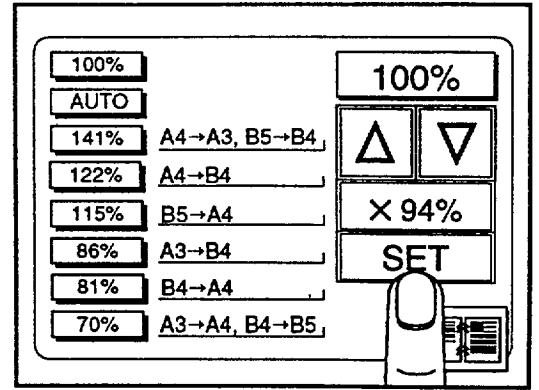

5 Open the Document Cover.

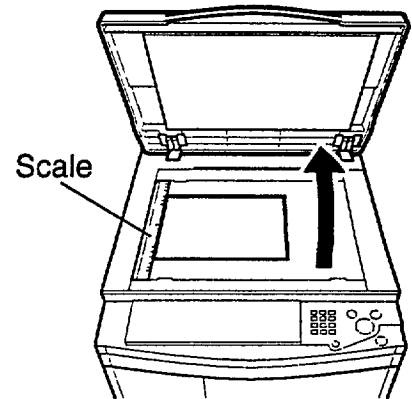

6 Align the document with the Scale Plate.

7 Gently close the Document Cover.

The Zoom ratio is displayed on the LCD Panel. The Auto Zoom ratio is automatically selected from among the fixed enlargement/reduction ratios shown below. When the size of the document being copied or the copy paper being used warrants an enlargement/reduction ratio other than those shown here, the printer selects that ratio closest to the one required.

- 141% A4 → A3/B5 → B4
- 122% A4 → B4
- 115% B4 → A3/B5 → A4
- 86% A3 → B4
- 81% B4 → A4
- 70% A3 → A4/B4 → B5

IMPORTANT

- Be sure to select the correct paper size.
- If you select the wrong size, the correct zoom factor cannot be selected.
- With the DP-43E/33E/31E, the paper size is detected along a line about 30 mm from the scale (the shaded portion in the figure). This means that if you position the document in one of the ways shown below, an incorrect zoom factor could be selected.

• Document not positioned centrally against the scale.

• Edge of paper not touching scale.

• Paper positioned sideways. Machine senses a paper size twice as large as actual size of paper.

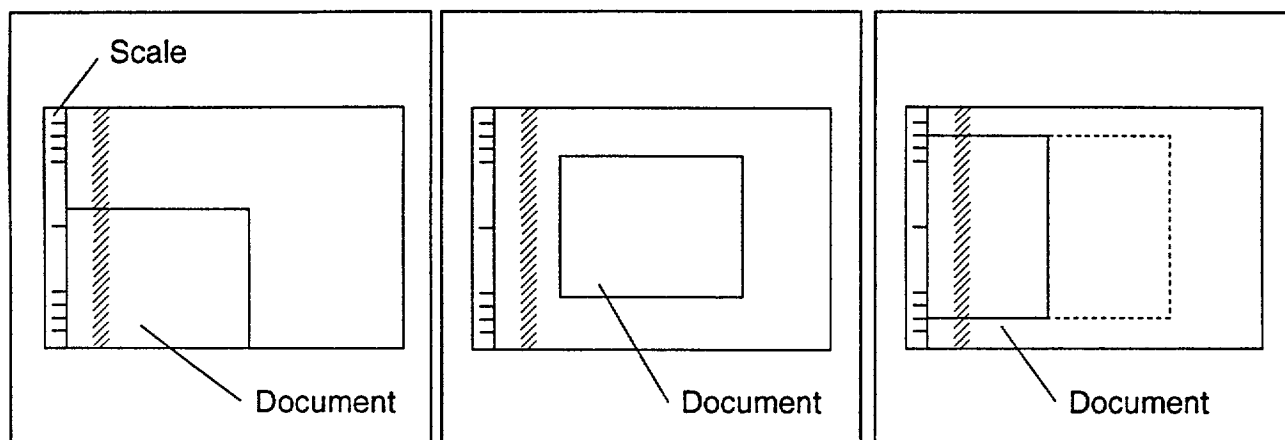

Zoom Setting Function (printing at a specified zoom factor)

Function

Set any zoom factor you like from 50 to 300% in 1% increments.

IMPORTANT

- The 94% reduction function cannot be used when the zoom setting function is used.

III Operation

1 Make sure the Main Screen is displayed.

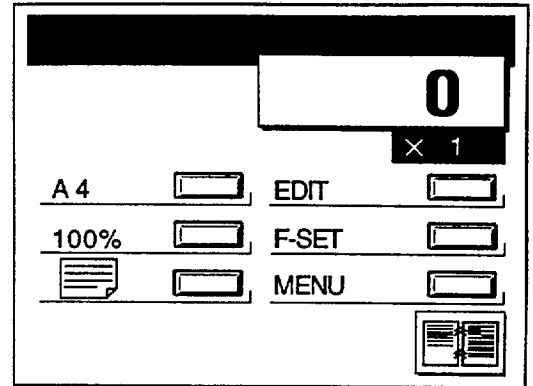

2 Press the [Enlargement/Reduction] key.



If the enlargement or reduction setting has already been made, that value will be displayed.

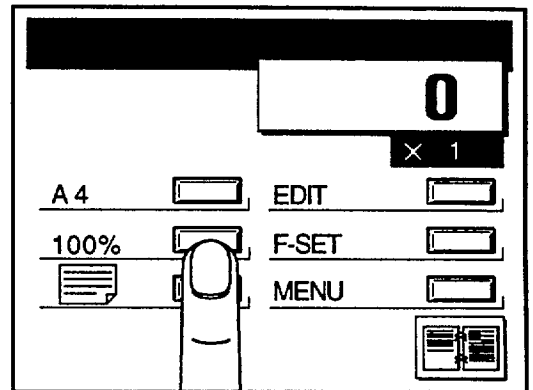

3 Press the \triangle or ∇ keys on the LCD Panel to set the enlargement/reduction ratio.

Press \triangle to enlarge the image, and press ∇ to reduce it.

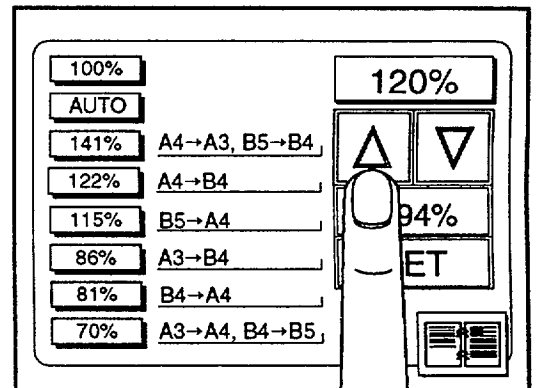

4 Select [SET].

This sets the enlargement/reduction ratio, and returns the LCD Panel to the Main Screen.

*To return to the standard setting
There are two ways of returning the setting to the standard setting.

- Reset the enlargement/reduction ratio back to 100%.
- When the "ALL CLEAR" key is pressed, all the settings will return to their defaults.

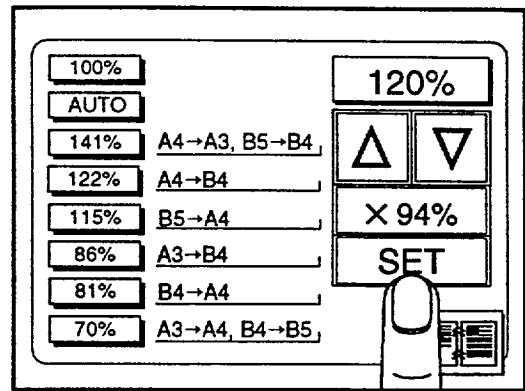

This function can be used in conjunction with zoom factor selection or auto zoom. That is, the zoom factor displayed when the zoom factor selection or auto zoom functions are operative can be changed to any desired value using the free zoom keys.

IMPORTANT

- When copies are made using a large zoom factor, letters and lines, etc may be jagged.

Printing Photographs/Color Documents

Function

This printer is equipped with printing modes that enable clean copies to be reproduced from various types of original documents, to include text documents, photographic documents and documents containing a mixture of text and photographs.

- Text Mode For text documents, and halftone dot black-and-white photograph documents.
- Photograph Mode For pastel colored documents, color photograph documents, and non-halftone dot black-and-white photograph documents.
- Text-Photograph Mode For documents containing a mixture of text and photographs.
- Text-Fine Lettering Mode For text documents containing particularly fine print.
- Photograph-Fine Lettering Mode For photograph documents that contain particularly fine print.
- Halftone Dot 1 Mode Performs halftone dot processing (Small halftone dots).
- Halftone Dot 2 Mode Performs halftone dot processing (Large halftone dots).
- Dark Photo Mode For detailing the gradations in the dark areas of photograph documents.



- Set these modes before starting Platemaking.

III Operation

1 Make sure the Main Screen is displayed.

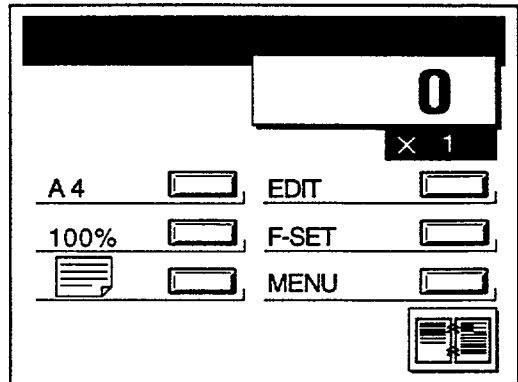

2 Press the [Text/Photograph Mode] key.

A window containing the various mode symbols is displayed on the LCD Panel.

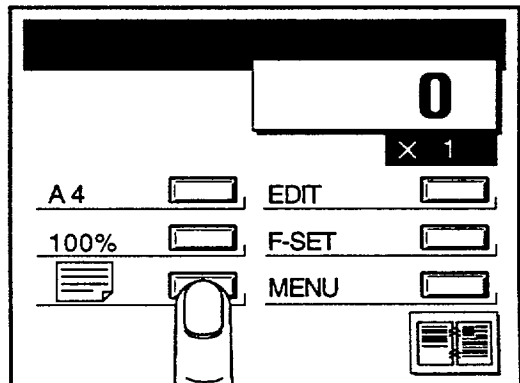

IMPORTANT

- If a mode other than the Text Mode has already been set, then the symbol for that setting is displayed.

3 Press the symbol of the mode you wish to set.

The mode you select is displayed in reverse video and the display returns to the Main Screen.

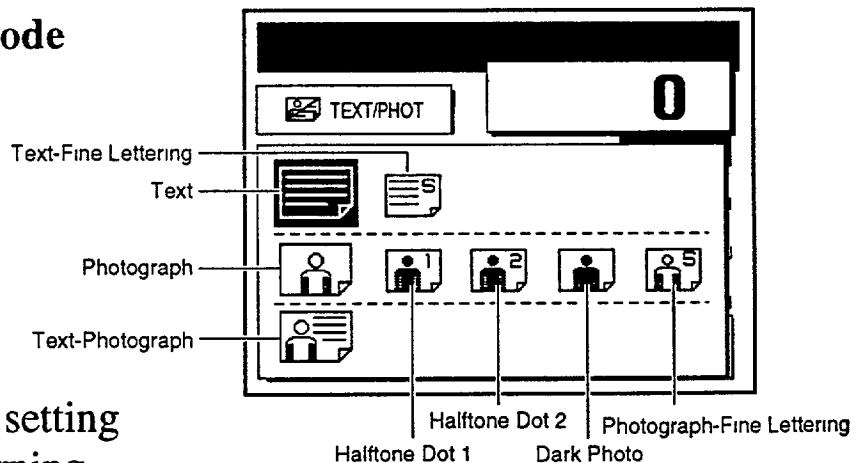

***** To return to the standard setting
There are two ways of returning the setting to the standard setting.

- Select Text once again.
- When the "ALL CLEAR" key is pressed, all the settings will return to their defaults.

Erasing Book Shadows (printing documents with shadows on the center or the edges erased)

Function

The book shadow eraser mode erases shadows on the center or the edges of book documents.



- Set the book shadow eraser mode before starting platemaking.

Operation

1 Make sure the Main Screen is displayed.

2 Select [MENU].

The Menu Screen is displayed.

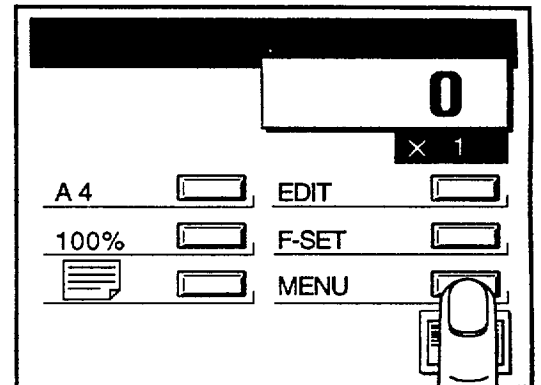

3 Select .

This symbol is displayed in reverse video, and the Book Shadow Eraser Mode is turned ON.

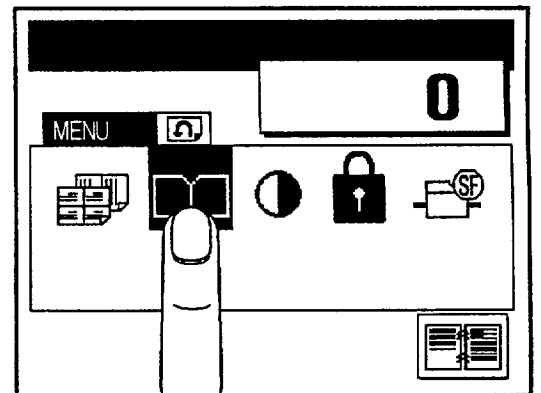

4 Press Return .

The display returns to the Main Screen.

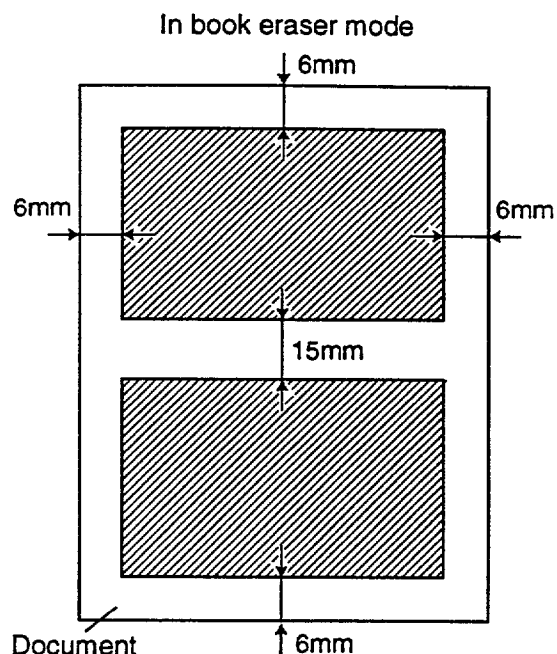
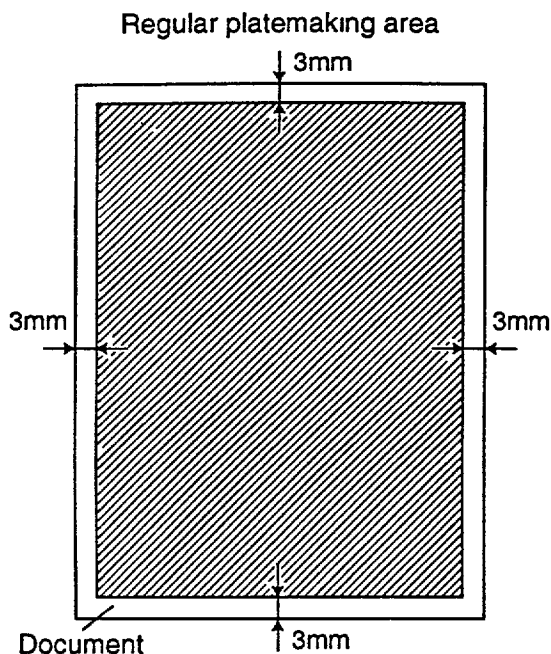

*** To return to the standard setting**

There are two ways of returning the setting to the standard setting.

- Select  from the Menu Screen once again to cancel the Book Shadow Eraser Mode.
- When the "ALL CLEAR" key is pressed, all the settings will return to their defaults.

Sectional Printing (stopping after each set)

Function

When "number of prints" " \times " "number of sets" " \times " are entered, printing will stop after each set. This allows you to print a document in sections.

You can enter up to 15 groups of number of prints x number of sets. Printing starts in order from the last entered set.

IMPORTANT

- The sectional printing can be set after platemaking.

Entering the Number of Prints and Number of Sets

III Operation

- 1 Enter the desired number of prints on the key pad.

Example: [2] [5]

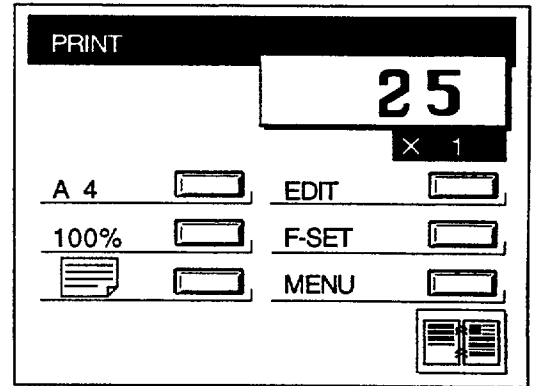

- 2 Press the " \times " key.

The number of sets is displayed under the number of prints. The current set is displayed to the lower left of the number of prints.
Example: [\times]

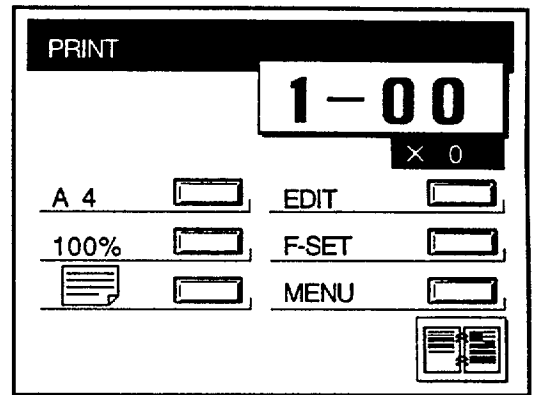

IMPORTANT

- If you make a mistake, start over again by pressing the "CLEAR" key and start from the beginning. When the "ALL CLEAR" key is pressed, all the numbers will be cleared.

- 3 Enter the number of sets on the key pad.

Example: [3]

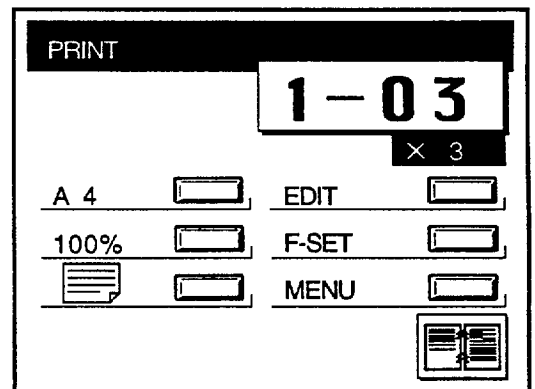

- 4 Press the " \times " key.

Example: [\times]

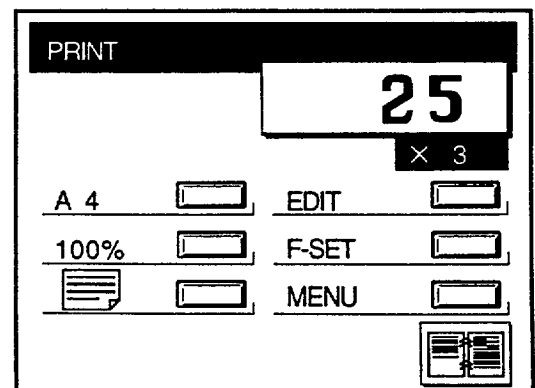

5 Continuously enter the number of prints $\underline{\quad}$, number of sets $\underline{\quad}$, number of prints $\underline{\quad}$, number of sets, etc.

Print

III Operation

1 Press the "PRINT" key.

Printing will start from the last entered set, and stop after the first set of printouts.

2 Collate by inserting a paper that acts as a marker or by removing the whole set from the machine.

3 Press the "PRINT" key.

Printing will resume.

4 Repeat steps 2 and 3 until all entered sets have been completed.

IMPORTANT

- The "PLATEMAKING" key will not work until all the sets are printed.
- To cancel printing midway, press the "CLEAR" key.

Sectional Printing (dividing sections with tape)

IMPORTANT

- The optional tape cluster is required for sectional printing.

III Function

Only the specified number of sets is printed with the specified number of prints taken as one set. Paper tape can be inserted when printing of each set is completed.

You can enter up to 15 groups of number of prints x number of sets. Printing starts in order from the last entered set.

IMPORTANT

- The sectional printing can be set after platemaking.

Enter the Number of Prints and Number of Sets

III Operation

1 Enter the desired number of prints on the key pad.

Example: [2] [5]

2 Press the "⊗" key.

The number of sets is displayed under the number of prints. The current set is displayed to the lower left of the number of prints.

Example: [⊗]

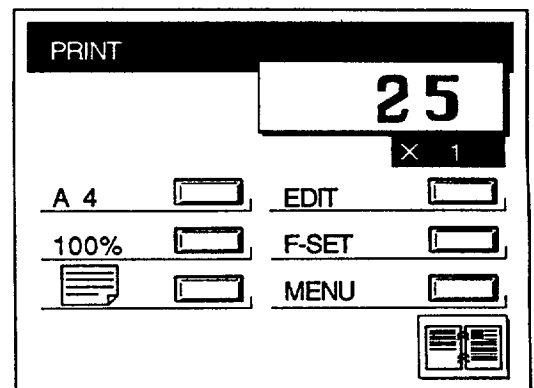

IMPORTANT

- If you make a mistake, start over again by pressing the "CLEAR" key and start from the beginning. When the "ALL CLEAR" key is pressed, all the numbers will be cleared.

3 Enter the number of sets on the key pad.

Example: [3]

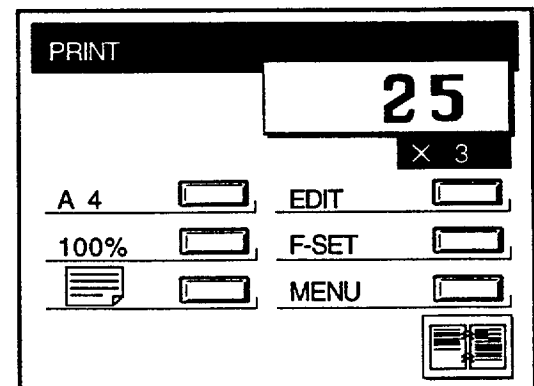

4 Press the "⌘" key.

Example: [⌘]

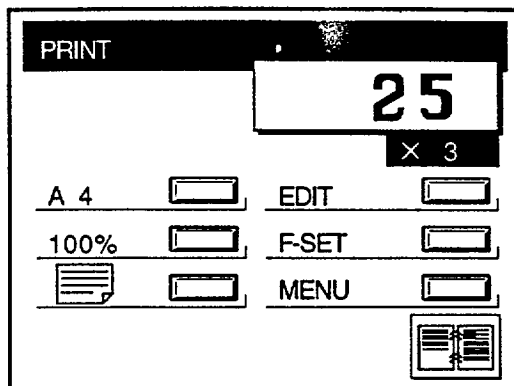

5 Continuously enter number of prints $\underline{\quad}$, number of sets $\underline{\quad}$, number of prints $\underline{\quad}$, number of sets, etc.

Print

IMPORTANT

- Printing cannot be stopped at the end of each set when the optional tape cluster is attached.

III Operation

1 Press the "PRINT" key.

Printing will start from the last entered set. After the end of each set, the tape will be inserted, and printing will continue. When the set changes, the longer tape will be inserted.

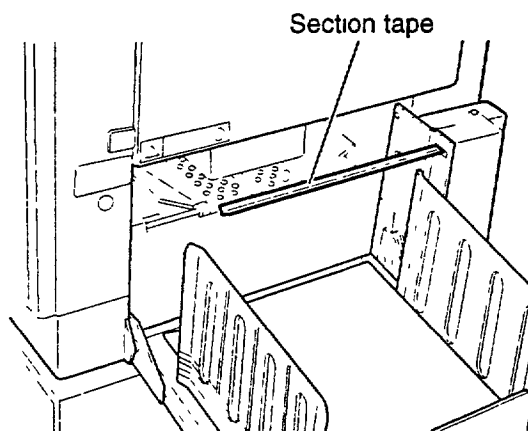

IMPORTANT

- The "PLATEMAKING" key will not work until all the sets are printed.
- To cancel printing midway, press the "CLEAR" key.

Sectional Printing (changing the number of prints with each document)

IMPORTANT

- Set sectional printing before starting platemaking.

Function

You can set separate the number of prints for up to 15 documents.

Operation

- 1 Refer to "Print Number Input Mode" in Chapter 3, "Special Functions," to change to the Print Number Input Mode.

When you change to the Print Number Input Mode, a black dot "•" appears in the lower right portion of the Counter display. This "•" indicates that the Print Number Input Mode is ON.

- 2 Press the "CLEAR" key.

- 3 Press the " \cong " key.

- 4 Enter the number of prints and sets on the key pad.

You can enter a different number of prints or sets for each document used. The machine will start printing from the last entered number of prints/number of sets.

 Chapter 3, "Sectional Printing (stopping after each set)"

IMPORTANT

- When using an ADF, start with the number of print/number of sets for the top document on the ADF.

5 Place the document on the platen.

IMPORTANT

- When using an ADF, place the document with the first entered number of prints/number of sets on top and the document with last entered number of prints/number of sets on the bottom.

6 Press the "PLATEMAKING" key.

Platemaking will start.

The machine will start printing from the last entered number of prints/number of sets.

7 When the document is printed, place the next document on the platen.

8 Press the "PLATEMAKING" key.

The next platemaking and printing processes will start.

IMPORTANT

- Plates or prints can be made continuously from multiple documents when the optional tape cluster and ADF are attached.

Multiple Image Printing (on one sheet from the same document)

Function

You can make two or more prints from one document on a single sheet of paper (2 up, 4 up, 8 up)

IMPORTANT

- Set multiple image printing before starting platemaking.

III Operation

1 Make sure the Main Screen is displayed.

2 Select **MENU**.

The Menu Screen is displayed.

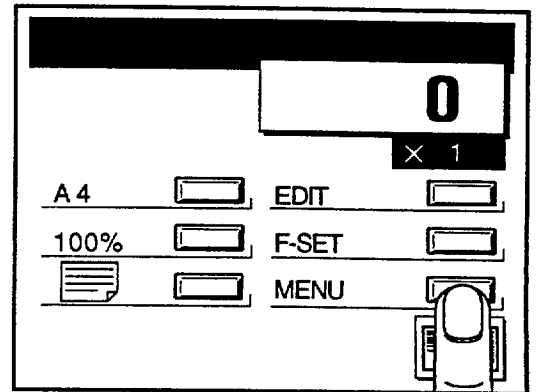

3 Select the  icon.

The Multiple Printing Screen is displayed.

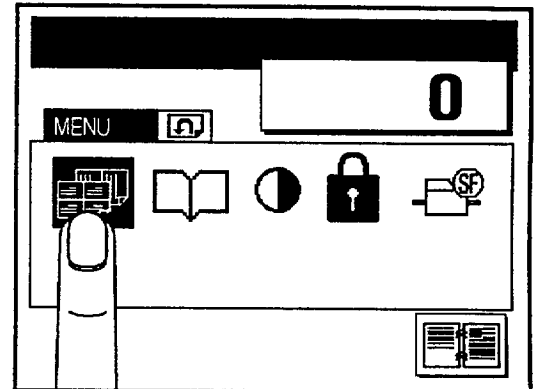

4 Select [Number of Images].

The number of images for Multiple Printing is set, and the display returns to the Menu Screen.

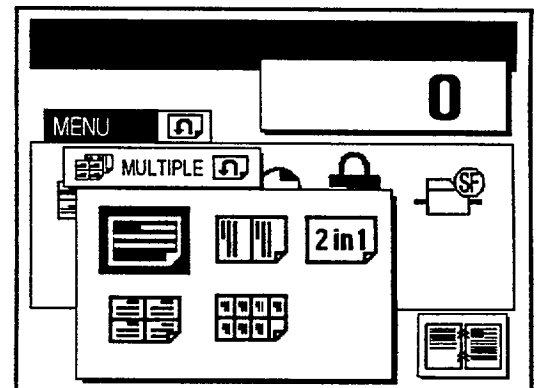



5 Press Return .

The display returns to the Main Screen.

6 Select the paper size.

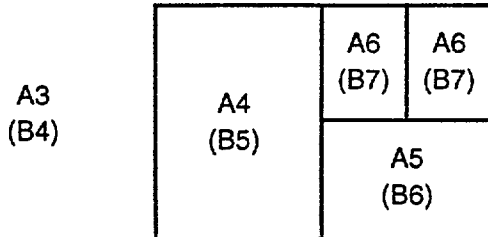
7 Use the following figure as a guideline for selecting the zoom factor when enlarging/reducing documents.





 Chapter 2, "Selecting the Paper Size"

IMPORTANT

- The printing range is slightly smaller than the paper size.
- The layout will not be correct if the paper size is not selected properly.

8 Press the "PLATEMAKING" key.

The machine will start to make plates.

- * To return to the standard setting
- Press the "ALL CLEAR" key. When the "ALL CLEAR" key is pressed, all control panel indicators will return to their defaults.
- Select the  icon from the Menu Screen, then select the  icon.

Printing with Two documents (ADF)

Function

The 2in1 layout mode is achieved by using the ADF to print two small documents onto one larger sheet of paper.

If your printer is equipped with an (optional) Automatic Document Feeder (ADF), you can also make use of the 2-in-1 Layout Mode.

This is useful for creating booklets that will be saddle stitched.

IMPORTANT

Be sure to take the following precautions when using a 2in1 layout mode:

- The document must lie vertically on the ADF.
- Select an enlargement/reduction and paper size that enables both documents to fit on one sheet of paper.
- Non-standard sized documents may cause problems in the layout.

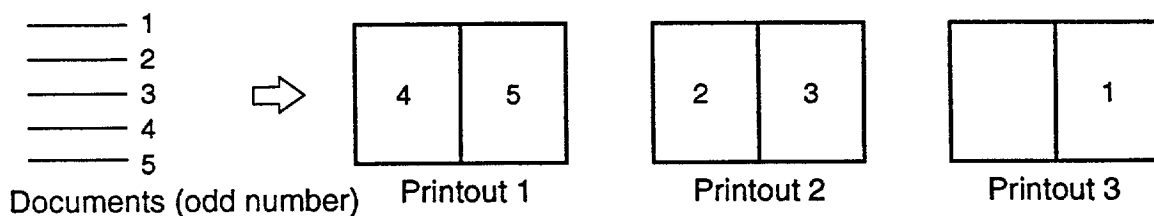
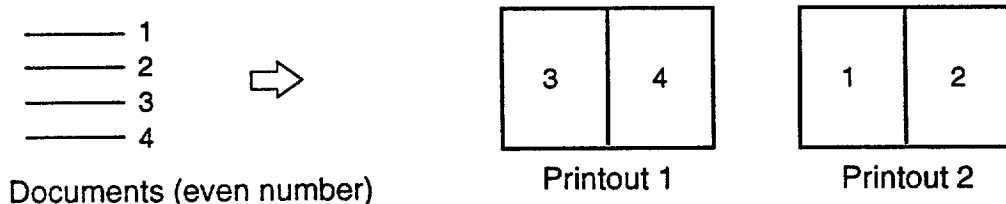



III Operation

1 Make sure the Main Screen is displayed.

2 Select [MENU].

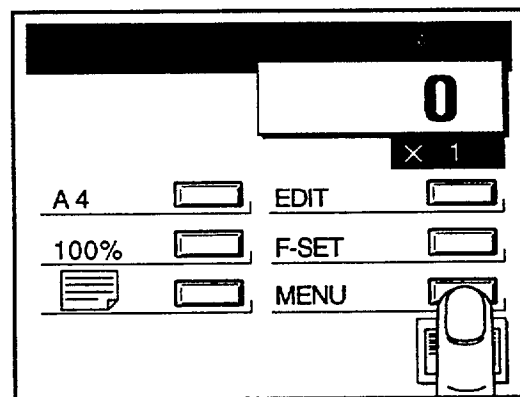
The Menu Screen is displayed.



3 Select the  icon.

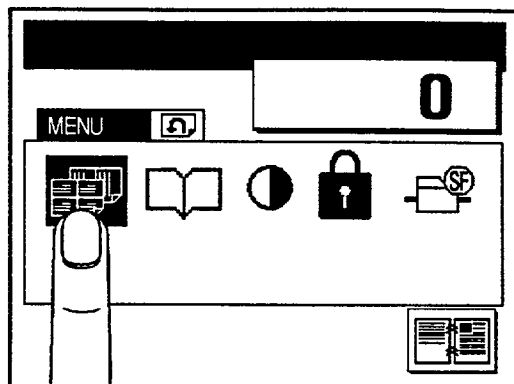

4 Select the [2in1] icon.

This sets 2-in-1 Printing, and the display returns to the Menu Screen.

5 Press Return .

6 Select the paper size.

If you want the print size to be the same size as the document size, use the paper twice as big as the document.

Select the enlargement/reduction size if necessary.

When enlarging/reducing two documents placed side by side, select the zoom factor so that the copies fit just inside the size of the printing paper.

 Chapter 2, "Selecting the Paper Size"

7 Set the documents to be copied in the ADF.

Place the documents in the ADF vertically (the top edges of the documents should be toward the rear of the printer) with the sides to be copied facing up. There is no need to turn the documents upside-down or to rearrange their sequence.

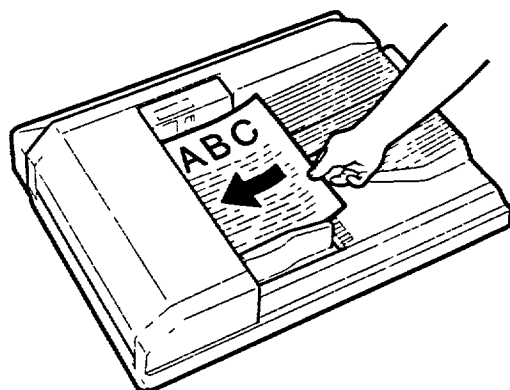

IMPORTANT

- The ADF cannot handle documents larger than 210 mm.
- Documents of different sizes cannot be used in the ADF at the same time.
- The use of documents of non-standard size/shape can cause layout problems.

8 Press the "PLATEMAKING" key.

The machine will start to make plates.

The ADF will feed two documents consecutively.

IMPORTANT

- If the layout was not correct, check the following:
 - Check the direction of the document.
 - Check the document size, paper size selection and printing size.

Confidential Safeguard Function (preventing others from making copies)

III Function

By simple procedure, others can be prohibited from printing sensitive documents. This is called the "Confidential Safeguard function."

- When the Confidential Safeguard function is turned ON, printing cannot be performed with the "PRINT" or "TEST PRINT" keys.
- Turning the power OFF will not turn the Confidential Safeguard function OFF.
- Platemaking still functions even if the Confidential Safeguard function is ON. Normal operations other than print or test print can be performed.
- Once platemaking is carried out, the Confidential Safeguard function will be cleared.

III Operation

1 Make sure the Main Screen is displayed.

2 Select [MENU].

The Menu Screen is displayed.

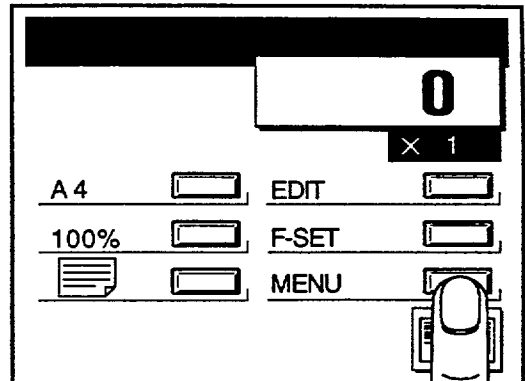

3 Select .

This sets the Confidential Safeguard Mode.

4 Press Return .

The display returns to the Main Screen.

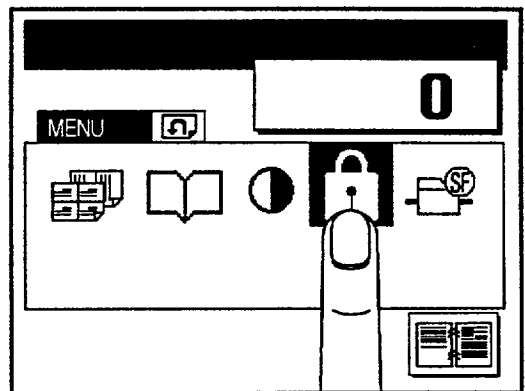

5 Make sure that the "TEST PRINT" key will not start the printing process.

The message (shown below) will be displayed when the PRINT or "TEST PRINT" key is pressed with Confidential Safeguard function ON.

**PLEASE PLATE
MAKING**

* To clear

Press the "PLATEMAKING" key to carry out platemaking. Once platemaking is carried out, the Confidential Safeguard function is turned OFF.

The Confidential Safeguard function cannot be canceled by pressing the "CONFIDENTIAL SAFEGUARD" key.

Total Counter (displaying the total number of plates and prints made)

Function

The total number of prints and plates can be displayed on the LED panel.

IMPORTANT

- Make sure that the machine is not printing.
- To cancel printing midway, press the "STOP" key.

Operation

1 Press the "STOP" key.

The total count is displayed while the "STOP" key is held down. The total number of prints is displayed in the top row, and the total number of plates is displayed in the bottom row. The following example shows "1234500" as the total number of prints and "12345" as the total number of plates made so far.

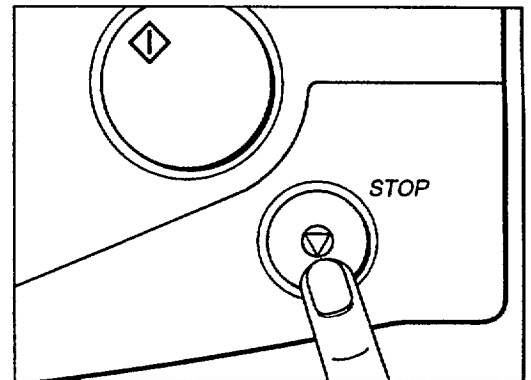

P	1234500
F	12345

Special Functions

Function

Allows you to change Standard Mode settings.

Those settings capable of being changed are as follows:

- Fine Start
- Auto Clear
- Preprint
- Print Number Input Mode
- Change Initial Setting

Fine Start

Function

Enables you to set the printer in the Fine Start Mode.

This printer employs a mechanism that forces ink out from inside the drum. The Fine Start Mode automatically checks the time elapsed since the printer was last used and the room temperature, and then selects the optimal operational settings to ensure the first page is printed clearly and vividly.

IMPORTANT

- When the Fine Start Mode is functioning, it may take longer than usual for the first page to be printed out following platemaking.
- When the temperature is below 10 °C, the first few pages printed out may not be imaged perfectly even when the Fine Start Mode is ON.

Operation

1 Make sure the Main Screen is displayed.

2 Select [MENU].

The Menu Screen is displayed.

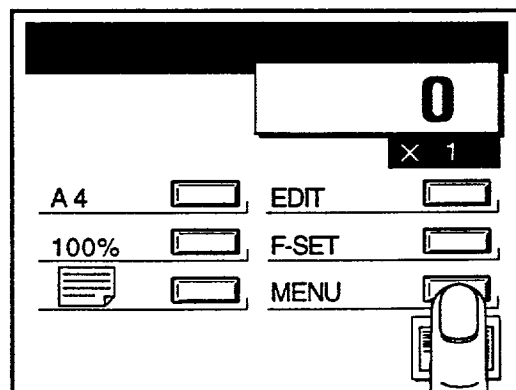

3 Select the  icon.

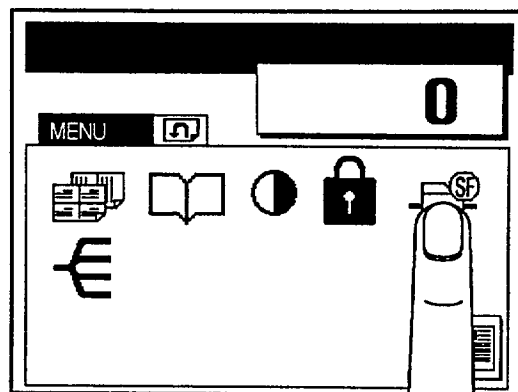

4 Press the  or  key until [1. FINE START] is displayed.

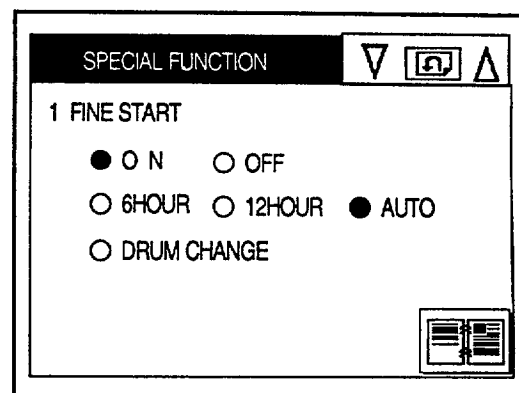

5 Press the [ON] or [OFF] key to turn the Fine Start Mode ON or OFF.

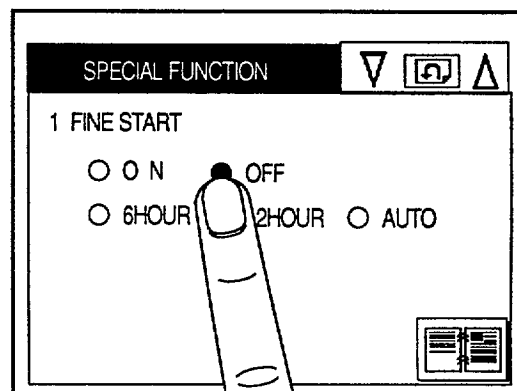

6 Press the  key.

The display returns to the Main Screen.

Auto Clear

Function

Automatically clears the display (settings) on the control panel when printing is not performed for a specified period of time (The same thing happens when the power is turned ON, or the Clear key is pressed). The specified time period can be set for 3, 10 or 30 minutes.

Operation

1 Make sure the Main Screen is displayed.

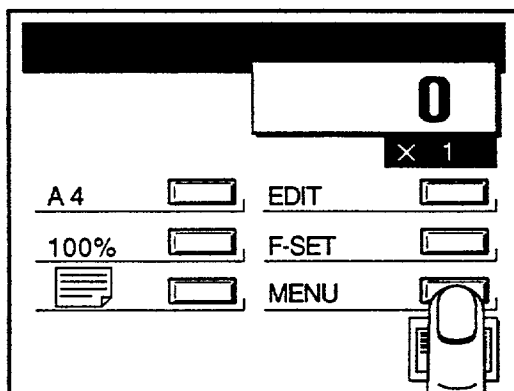

2 Select [MENU].

The Menu Screen is displayed.

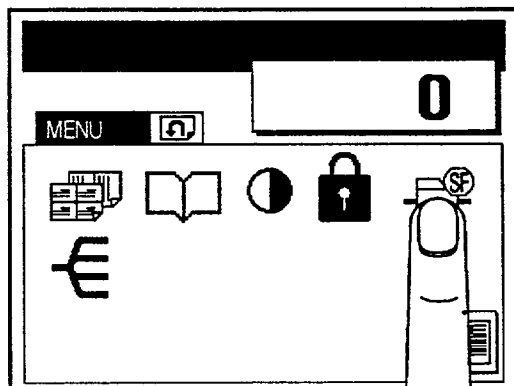

3 Select the  icon.



4 Press the  or  key until [2. AUTO CLEAR] is displayed.

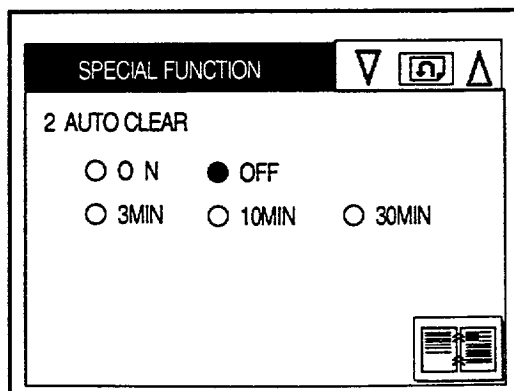

5 Press the [ON] key, then press the desired time key.

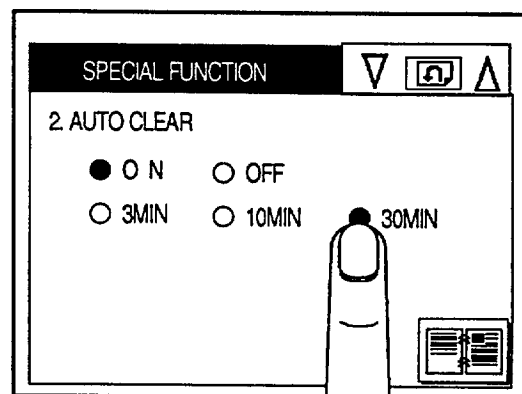

6 Press the [MENU] key.

The display returns to the Main Screen.

Preprint

Function

Disables the Count function for a specified number of pages following the commencement of a printing operation. For example, if you set the Preprint Mode to three (3) pages, the Count function will ignore the first three pages printed, and will start counting from the fourth printed page.

IMPORTANT

- When the sorter is being used (Sort Mode, Group Mode), the number of pages set in the Preprint Mode will be output to the Nonsort bin.

Operation

1 Make sure the Main Screen is displayed.

2 Select [MENU].

The Menu Screen is displayed.

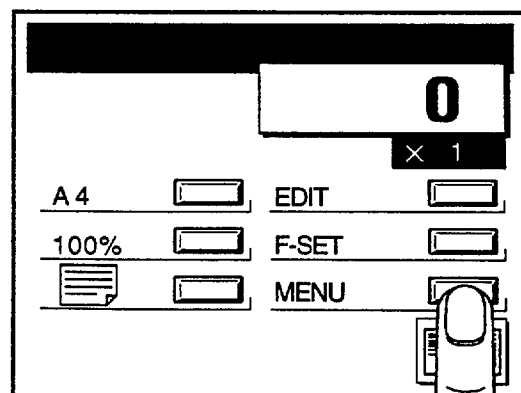

3 Select the  icon.

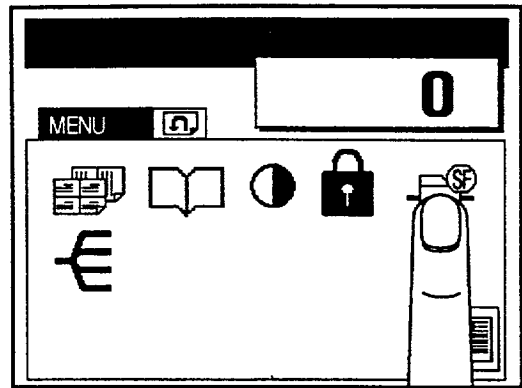

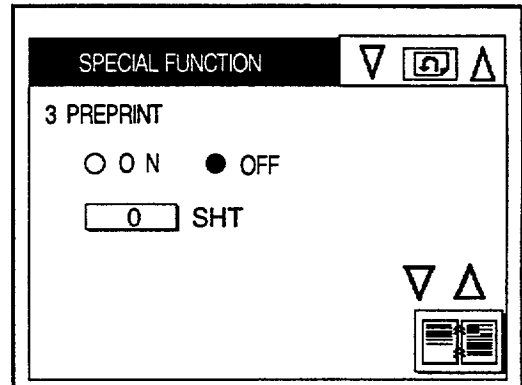

4 Press the  or  key until [3. PREPRINT] is displayed.

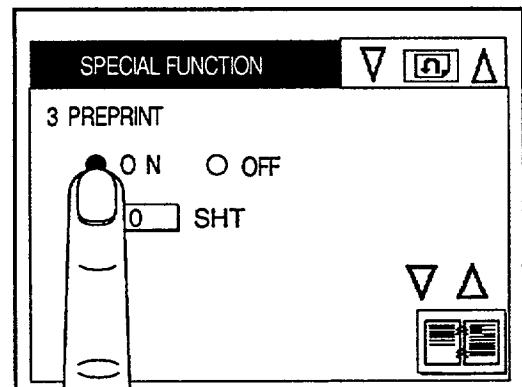

5 Press the [ON] key.



6 Use the  or  keys in the lower right corner of the LCD Panel to set the number of pages to be preprinted.

Pressing the  key decreases the number of Preprint pages by one.

Pressing the  key increases the number of Preprint pages by one.

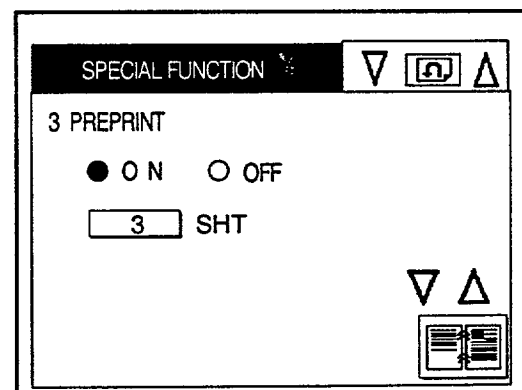

7 Press the  key.

The display returns to the Main Screen.

Print Number Input Mode

Switches from the normal "Number of Sets Mode" to the "Print Number Input Mode." The Number of Sets Mode prints out all sets input (number of copies * number of sets) from the same original document. With the Print Number Input Mode, each set corresponds to a different original document.



III Operation

1 Make sure the Main Screen is displayed.

2 Select [MENU].

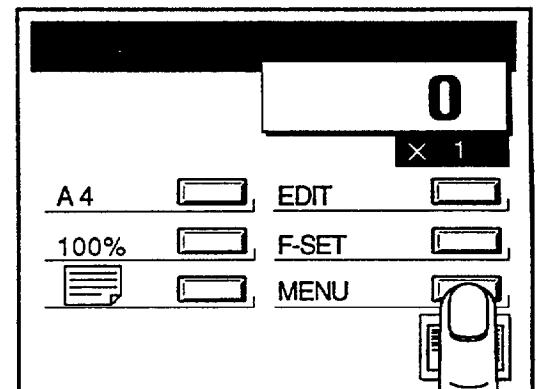
The Menu Screen is displayed.



3 Press the  or  key until [4. PRINT NUMBER INPUT MODE] is displayed.

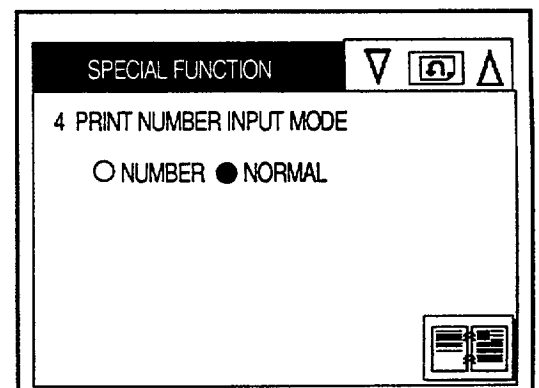

4 Press the [NUMBER] key.

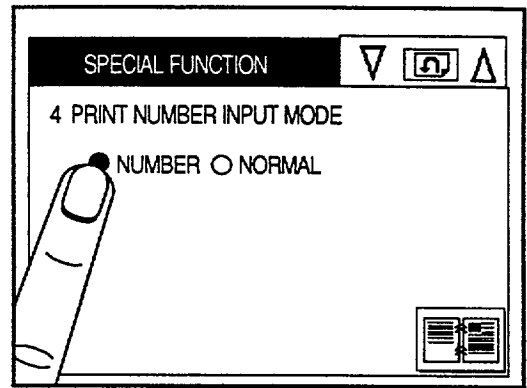

5 Press the  key.

Change Initial Setting

Enables you to change the paper selection setting when the power is turned ON, the Clear key is pressed or an Auto Clear operation is performed.

III Operation

1 Make sure the Main Screen is displayed.

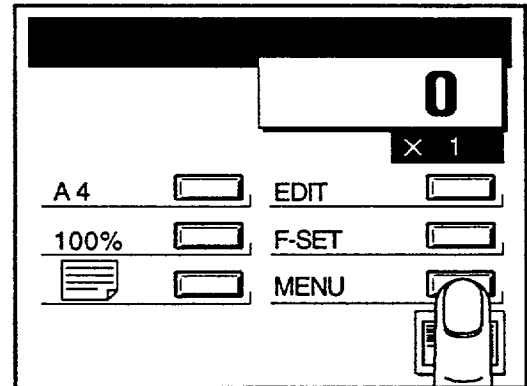

2 Select [MENU].

The Menu Screen is displayed.

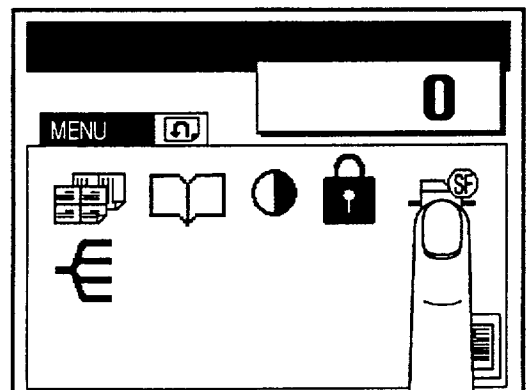

3 Select the  icon.



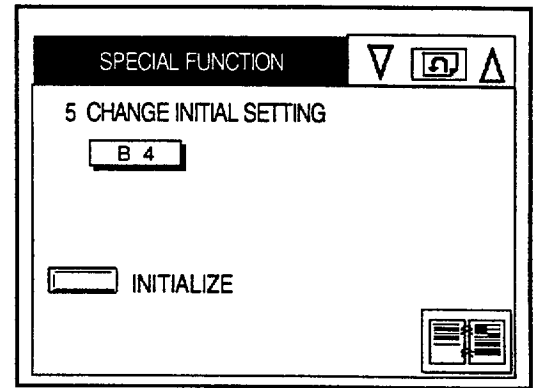

- 4** Press the  or  key until [5. CHANGE INITIAL SETTING] is displayed.

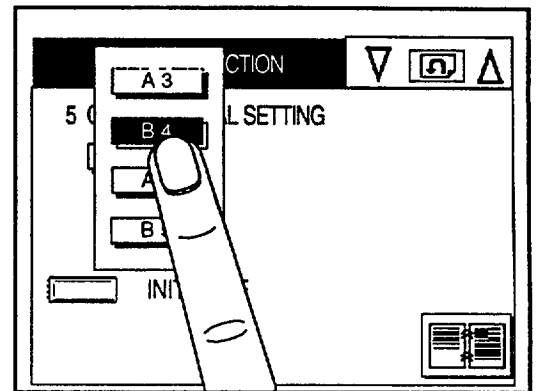

- 5** Press the [Paper Size] key (B4 in this case).

- 6** Now press the desired paper size setting key.



- 7** Press the  key.

The display returns to the Main Screen.

4. Function Mode

The Function Mode enables information pertaining to enlargement/reduction, paper size, multiple printing, number of copies, makeup, etc. to be stored and/or called up (read out). A total of three sets of settings can be stored/called up.

Function Mode Screens and Their Features

Function

1 Make sure the Main Screen is displayed.

2 Select [F-SET].

The Function Mode screen is displayed.

Function Mode Screen

Screen A

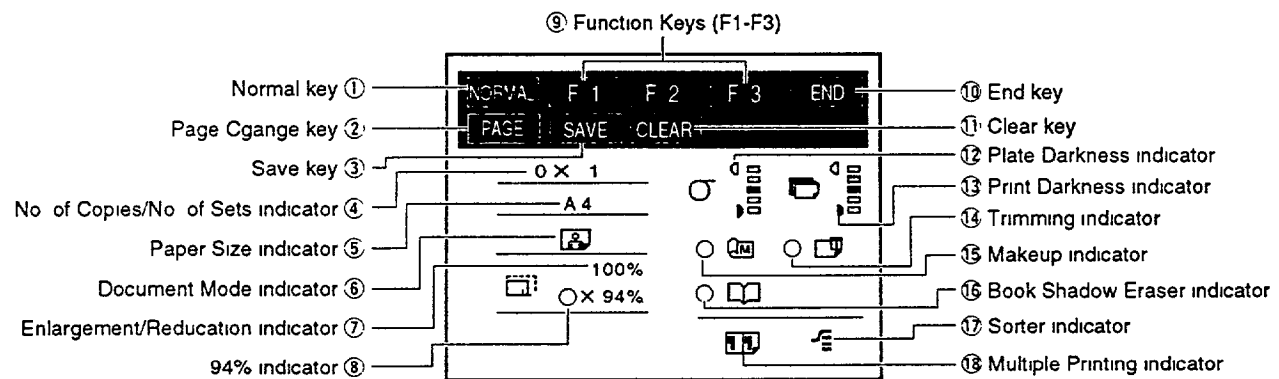

No.	Name	Feature
①	Normal key	Clears the Function Mode.
②	Page Change key	Changes from Screen A to Screen B and vice versa
③	Save key	Stores settings under Function keys F1 through F3
④	No of Copies/No of Sets indicator	Indicates the number of copies and sets that have been set
⑤	Paper Size indicator	Indicates the Paper Size setting.
⑥	Document Mode indicator	Indicates the Document Mode setting
⑦	Enlargement/Reduction indicator	Indicates the Enlargement/Reduction setting

Function Mode Screens and Their Features

No.	Name	Feature
⑧	94% indicator	A black dot "•" indicates the 94% Reduction Mode is ON
⑨	Function Keys (F1-F3)	Allow information pertaining to enlargement/reduction, paper size, multiple printing, number of copies, makeup, etc to be stored in advance, and then called up as needed for printing operations.
⑩	End key	Terminates Function setting operation
⑪	Clear key	Clears settings stored in memory under Function Keys F1-F3. Pressing the Clear key returns the Function Keys to their default settings.
⑫	Plate Darkness indicator	Indicates the Plate Darkness (contrast) setting
⑬	Print Darkness indicator	Indicates the Print Darkness setting
⑭	Trimming indicator	A black dot "•" indicates the Trimming Mode is ON.
⑮	Makeup indicator	A black dot "•" indicates the Makeup Mode is ON.
⑯	Book Shadow Eraser indicator	A black dot "•" indicates the Book Shadow Eraser Mode is ON.
⑰	Sorter indicator	Indicates the Sorter Mode setting (Indicator only functions when the sorter is hooked up)
⑱	Multiple Printing indicator	Indicates the Multiple Printing Mode setting

Screen B

NORMAL	F 1	F 2	F 3	END
PAGE	SAVE	CLEAR	MODIFY	
1.	1 X 1	1	9.	9 X 9
2	2 X 2	2	A	10 X 10
3	3 X 3	3	B	11 X 11
4	4 X 4	4	C	12 X 12
5	5 X 5	5	D	13 X 13
6	6 X 6	6	E	14 X 14
7	7 X 7	7	F:	15 X 15
8	8 X 8	8	○	NUMBER OF PRINTS

No.	Name	Feature
⑱	Modify key	Allows the No. of Copies/No of Sets to be revised
⑳	Number of Prints	A black dot {symbol} indicates that the Print Number Input Mode is NUMBER

Saving

Function

Stores current settings.

IMPORTANT

- When a setting is stored in memory under a Function Key, data saved to that memory location previously is deleted and written over.

Operation

1 Set all information to be saved in advance.

2 Make sure the Main Screen is displayed.

3 Select [F-SET].

Current settings are displayed on the LCD panel. Press the [PAGE] key to check the Number of Sets setting on Screen B.

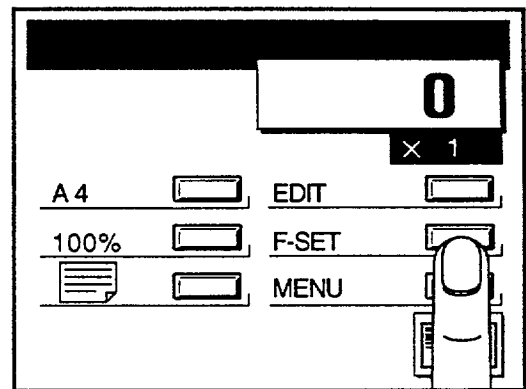

4 If the settings appearing on the LCD panel are correct, select [SAVE].

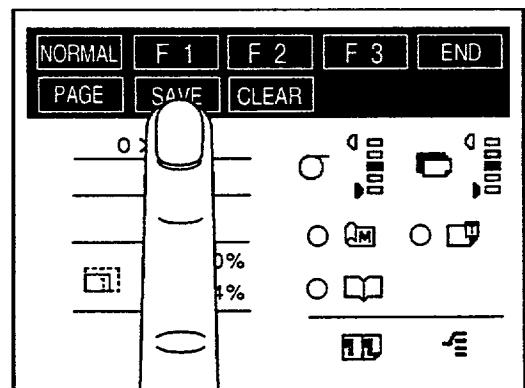

5 Select one of the Function Keys, F1, F2 or F3.

The setting will be stored in memory under the Function Key selected. For demonstration purposes, F1 is shown being selected here.

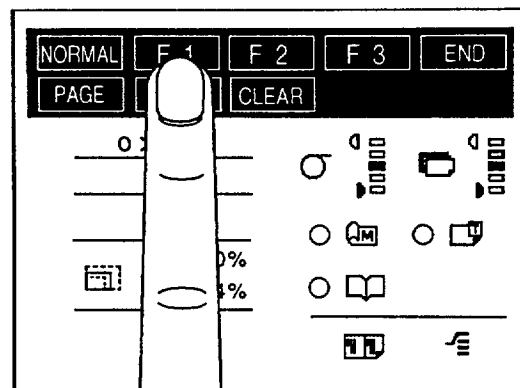

6 Select [END].

The display returns to the Main Screen.

Calling

Function

Calls saved settings.



- If Makeup and Trimming settings are stored in memory under the Function Keys, calling up these settings will simultaneously initiate a document scanning operation. Be sure an original document is set in the printer in advance.

Operation

1 Make sure the Main Screen is displayed.

2 Select [F-SET].

Current settings are displayed on the LCD panel.

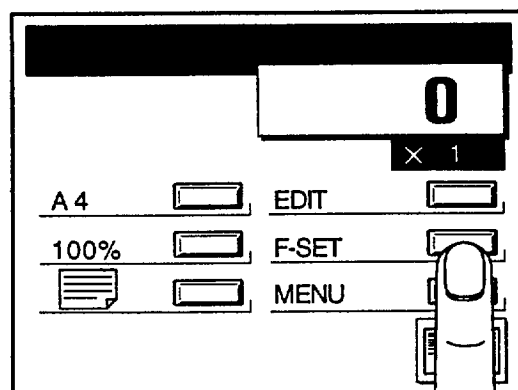

3 Select the function you wish to call up.

Here we have selected F1.

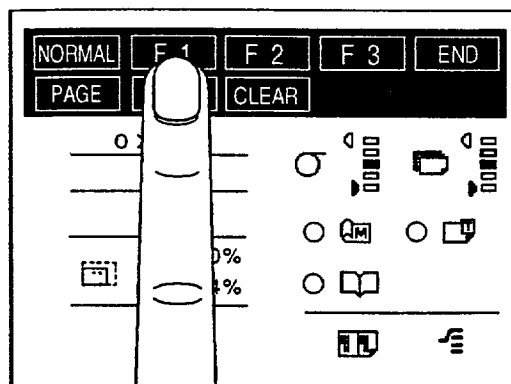

The selected setting information is called up and displayed on the LCD panel.

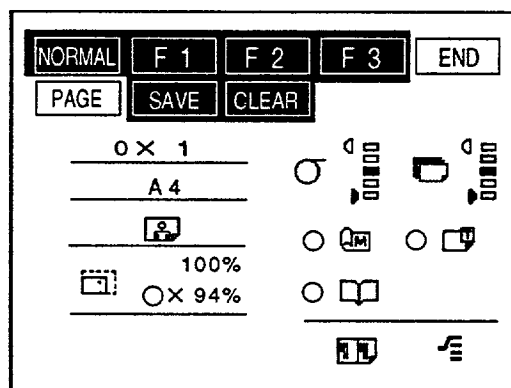

4 Select [END].

The display returns to Main Screen.

Clearing

Function

Deletes the settings stored in memory under Function Keys F1-F3. Once these settings have been deleted, the Function Keys return to their default settings.

Operation

1 Make sure the Main Screen is displayed.

2 Select [F-SET].

Current settings are displayed on the LCD panel.

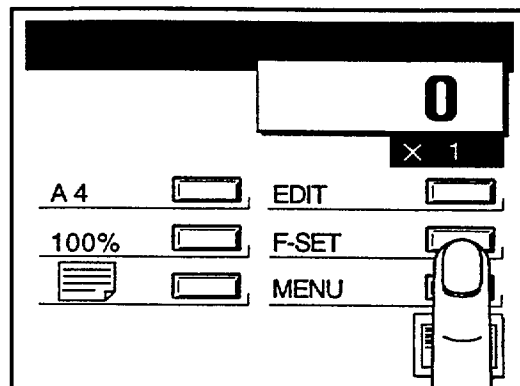

3 Select [CLEAR].

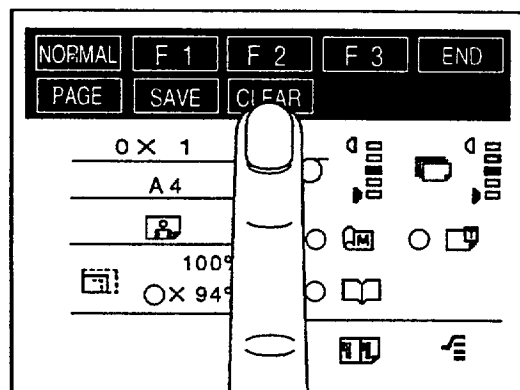

4 Select the function whose settings you wish to clear.

Here we have selected F1. The setting information stored in memory under this Function Key is deleted.

Modifying Number of Copies/Sets

Function

Modifies the number of copies and sets.

Operation

1 Make sure the Main Screen is displayed.

2 Select [F-SET].

Current settings are displayed on the LCD panel.

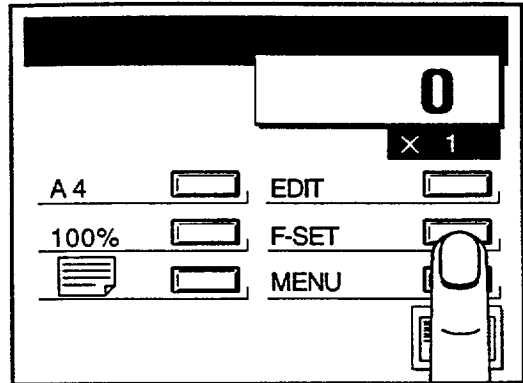

3 Select [PAGE].

The number of copies and sets are displayed.

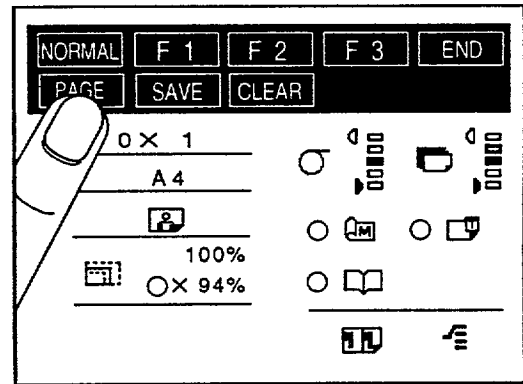

	NORMAL	F 1	F 2	F 3	END
	PAGE	SAVE	CLEAR	MODIFY	
1.	1 X 1	1	9:	9 X 9	
2	2 X 2	2	A.	10 X 10	
3	3 X 3	3	B	11 X 11	
4	4 X 4	4	C	12 X 12	
5	5 X 5	5	D	13 X 13	
6	6 X 6	6	E	14 X 14	
7	7 X 7	7	F:	15 X 15	
8	8 X 8	8	○	NUMBER OF PRINTS	

4 Select [MODIFY].

	NORMAL	F 1	F 2	F 3	END
	PAGE	SAVE	CLEAR	MODIFY	
1	1 X 1	1	9:	9 X 9	
2	2 X 2	2	A	10 X 10	
3	3 X 3	3	B	11 X 11	
4	4 X 4	4	C	12 X 12	
5:	5 X 5	5	D	13 X 13	
6:	6 X 6	6	E	14 X 14	
7	7 X 7	7	F:	15 X 15	
8	8 X 8	8	○	NUMBER OF PRINTS	
*SELECT A NUMBER					

5 Select the number of you wish to modify.

The number of copies and sets displayed beside the selected number return to zero (0), and the system enters the Input Standby Mode.

NORMAL	F 1	F 2	F 3	END
PAGE	SAVE	CLEAR	MODIFY	
1:	0 X 0			9 X 9
2:	2 X 2			10
3	3 X 3	B		
4:	4 X 4	C:	12 X	
5	5 X 5	D:	13 X 13	
6:	6 X 6	E	14 X 14	
7:	7 X 7	F	15 X 15	
8	8 X 8	○ NUMBER OF PRINTS		
*INPUT NUMBER ON TEN-KEY				

IMPORTANT

- When the No. of Copies is 0, revision is not possible.

6 Use the ten-key pad to input the modified number of copies and sets.

Inputting can be done by entering the number of copies and pressing [X] and then entering the number of sets and pressing [X]. Here, for demonstration purposes, we entered the 90 copies, and 9 sets.

IMPORTANT

- Input other than that via the ten-key pad cannot be performed until the final [X] has been entered.

7 Select [MODIFY].

This ends the operation for modifying the number of copies and sets.

NORMAL	F 1	F 2	F 3	END
PAGE	SAVE	CLEAR	MODIFY	
1:	1 X 1	9:	9 X	
2	2 X 2	A	10 X 10	
3	3 X 3	B	11 X 11	
4	4 X 4	C:	12 X 12	
5	5 X 5	D:	13 X 13	
6:	6 X 6	E:	14 X 14	
7	7 X 7	F	15 X 15	
8	8 X 8	○ NUMBER OF PRINTS		
*SELECT A NUMBER				

8 Repeat steps 4 through 6 until all the copy and set numbers you wish to change have been modified.

5. Editing Functions

This section explains Makeup, Zoom and other operations required to perform the various processes related to printing an original document.

Pen Input (Area Specification)

There are three methods for specifying the area where Editing Functions are to be used.

- Box Input Allows you to specify a box area.
- Polygon Input Allows you to specify an area with a maximum of 15 sides for intricate document layout operations.
- Paint Input Allows you to specify an area by filling it in using the input pen.

IMPORTANT

- Do not apply undue pressure to the LCD Panel.
- Do not use writing instruments other than the input pen that comes with the printer

Specifying a Box Area

Function

Allows you to specify a box area.

IMPORTANT

- When a portion of an area overlaps with another mode, the mode with the highest priority takes precedence.
- In order of priority, these modes are: 1. Masking 2. Reversing 3. Photograph 4. Outline Type*Pattern

Operation

1 Select [Box]

Tip To cancel an area specification, select [CLEAR]. The display will return to the Pen Input Specification Screen.

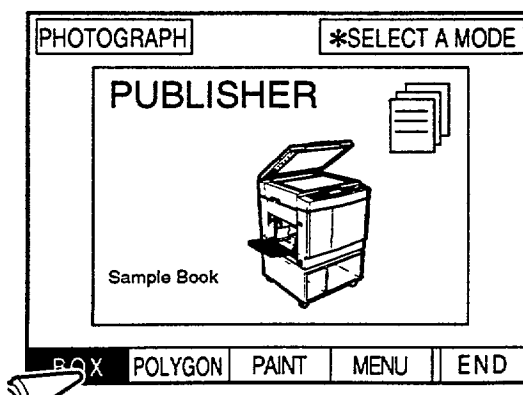

2 Press the pen lightly against the LCD Panel at the point where you want to start creating the Editing Area.

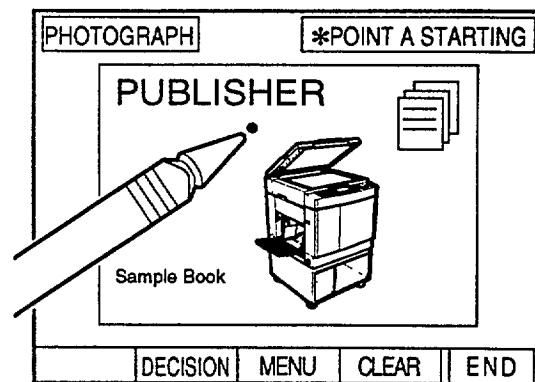

3 You designate the Editing Area by moving the pen across the LCD Panel, making sure the pen remains in contact with the Panel's surface.

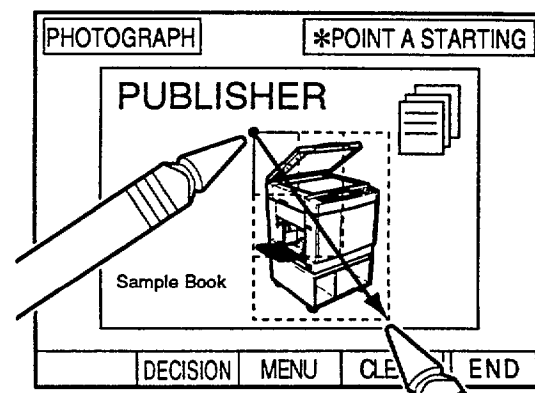

A box area is formed by moving the pen diagonally away from the starting point specified in Step 2.

4 Lift the pen when the area is large enough.

This process designates a tentative Editing Area. To modify this specification, repeat Steps 2 through 4.

5 Select [DECISION].

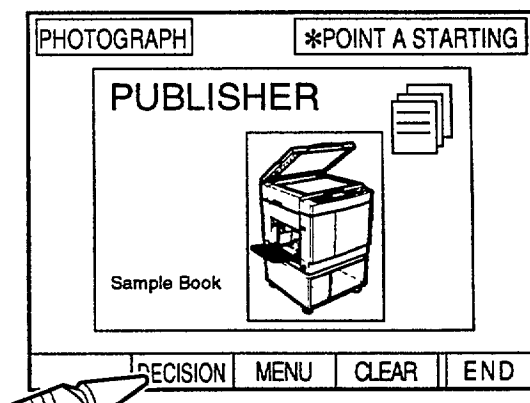

6 Touch the pen to the LCD Panel, either inside or outside of the specified area.

This establishes the area, and returns the display to the Pen Input Specification Screen.

Tip

Touching the pen outside the box area causes the entire area outside the rectangle to be made up in the current mode.

Specifying a Polygonal Area

III Function

Allows you to specify a polygonal area (You can specify an area with a maximum of 15 sides for intricate document layout operations.)

IMPORTANT

- When a portion of an area overlaps with another mode, the mode with the highest priority takes precedence.
- In order of priority, these modes are: 1. Masking 2. Reversing 3. Photograph 4. Outline Type*Pattern

III Operation

1 Select [POLYGON]

Tip

To cancel an area specification, select [CLEAR]. The display will return to the Pen Input Specification Screen.

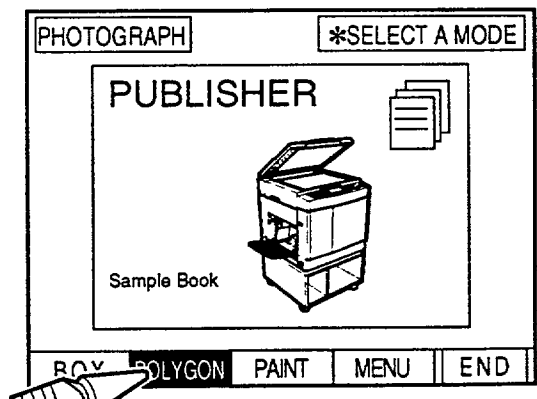

2 Press the pen lightly against the LCD Panel at the point where you want to start creating the area.

IMPORTANT

- Designate the apex of the polygon first so that the sides of the polygonal area do not intersect one another. A polygonal area cannot be specified properly if the sides intersect.

Tip

To re-specify an Editing Area, select [START]. This allows you to re-specify the area from the beginning.

3 Keeping the pen pressed against the LCD Panel, move it across the panel to the next angular point of the polygon, then lift the pen away from the Panel.

This specifies one side of the polygon.

4 Touch the pen lightly to the LCD Panel once again at the third angular point of the polygon.

A line will appear connecting the second and third angular points.

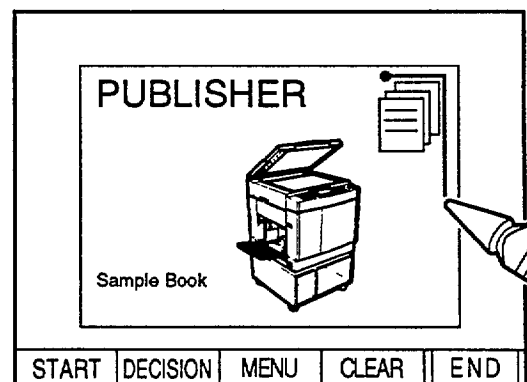
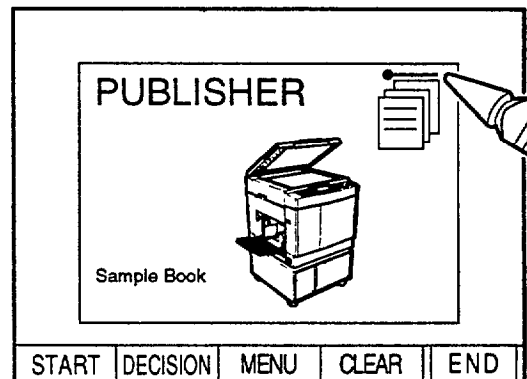
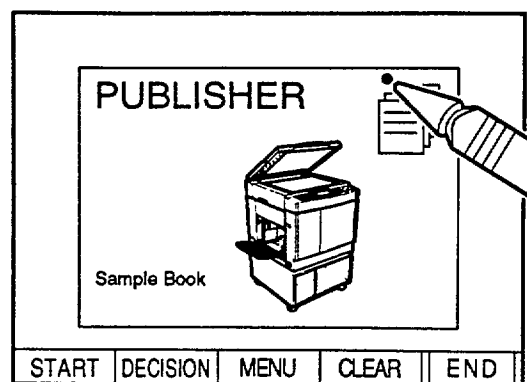

5 Moving the pen while keeping it pressed against the Panel causes the angular point to move in unison with the tip of the pen. You can remove the pen from the Panel at any point.

This specifies the second side of the polygon.

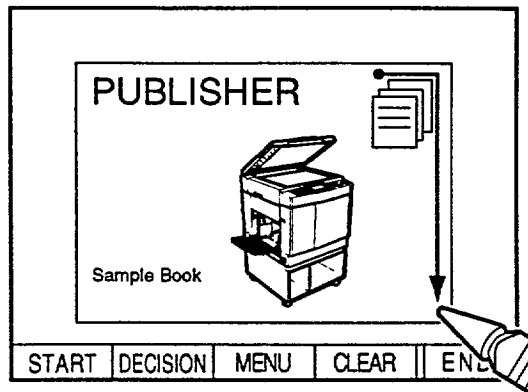

6 Repeat Steps 4 and 5 until all of the angular points of the polygonal area have been specified.

7 After specifying the final angular point, press [DECISION].

This connects the final angular point with the starting point, thus completing the polygonal area.

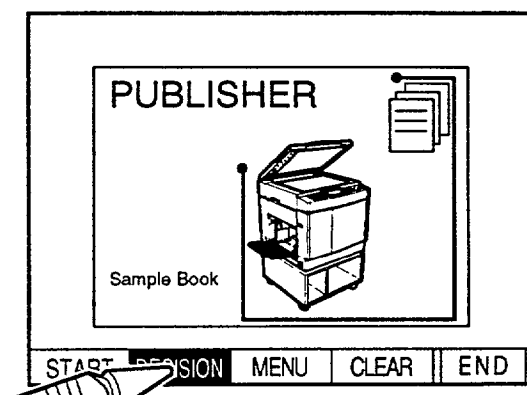

8 Touch the pen to the Panel, either inside or outside of the Editing area.

This establishes the area, and returns the display to the Pen Input Specification Screen.

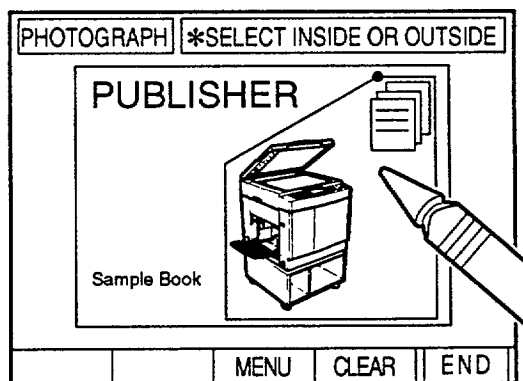

Touching the pen outside the polygonal area causes the entire area outside the polygon to be made up in the current mode.

Specifying an Area by Painting It

Function

Allows you to specify an Editing Area by filling it in using the pen.

IMPORTANT

- When a portion of an area overlaps with another mode, the mode with the highest priority takes precedence.
- In order of priority, these modes are:
 1. Masking
 2. Reversing
 3. Photograph
 4. Outline Type*Patterns

Operation

1 Select [PAINT].



To cancel an area specification, select [CLEAR]. The display will return to the Pen Input Specification Screen.

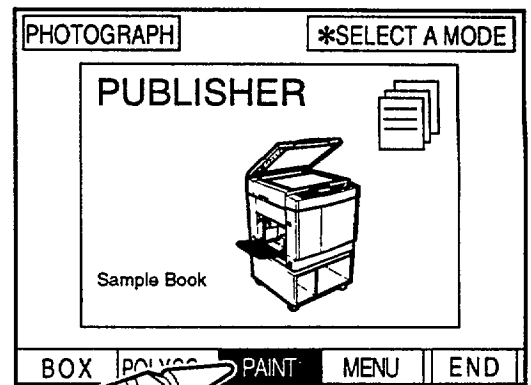

2 Select the pen size.

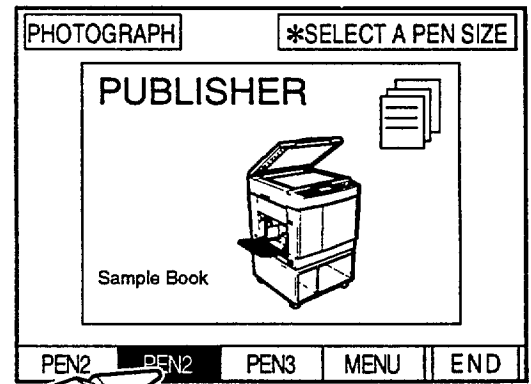

For demonstration purposes, Pen 2 has been selected here. The various pen sizes are as shown.

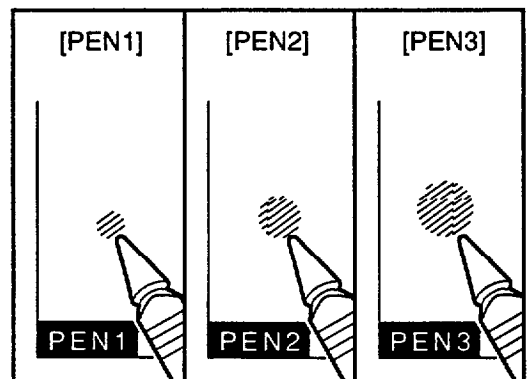

3 Use the pen to paint or fill in the area you wish to specify.

IMPORTANT

- Use the Zoom 3 screen to check whether or not you have completely filled in the area you want to specify.
 1. Select [MENU].
 2. Select [ZOOM].
 3. Select [ZOOM3].

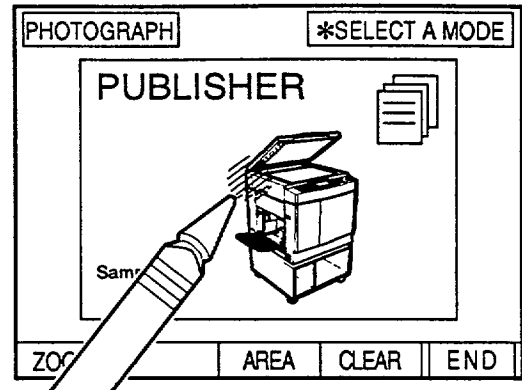

4 Select [MENU].

This establishes the area, and returns the display to the Pen Input Specification Screen.

To cancel an area specification, select [Cancel]. Selecting [Cancel] changes the display as shown below.

If you select [ALL CL], the entire area specified will be canceled.

If you select [PEN CL], only those portions of the area touched by the pen will be canceled.

Selecting [Area] returns the display to the Pen Input Specification Screen.

Tip

Zoom/Move

Zoom/Move Functions

The Zoom function allows you to enlarge, or zoom in on that portion of a document that you touch with the pen. The Zoom function offers three levels of magnification.

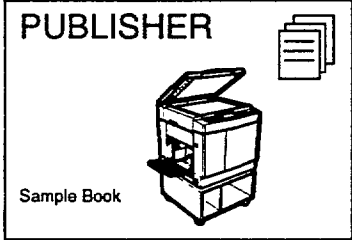
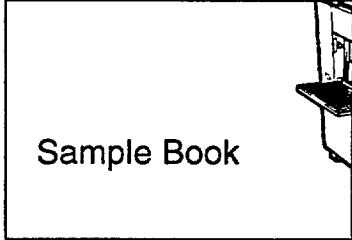
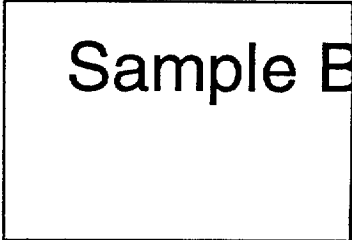
		
<p>Zoom 1 (Standard) Displays the entire document on the LCD Panel</p>	<p>Zoom 2 Zooms in on the point where the pen touches the LCD, enlarging the area displayed two fold over that of Zoom 1</p>	<p>Zoom 3 Zooms in on the point where the pen touches the LCD, enlarging the area displayed four fold over that of Zoom 1.</p>

The Move function allows you to move to any point on a document you wish to view with a simple touch of the pen. This function can be used in conjunction with Zoom 2 and Zoom 3.

Zooming

We will use the document shown here to explain how the Zoom function works.

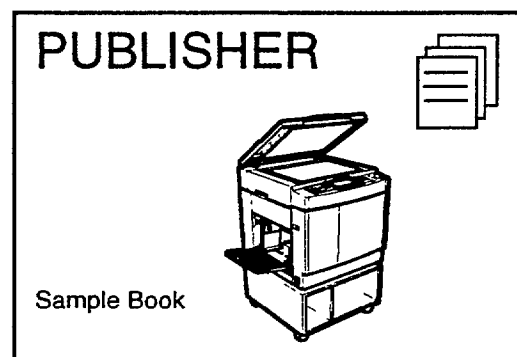

III Operation

- 1 Make sure the Main Screen is displayed.

2 Select [EDIT].

The Editing Monitor Screen is displayed.

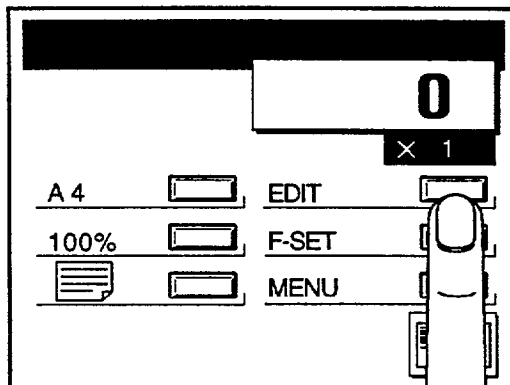

3 Select [MAKE-UP].

Selecting [NORMAL] clears Makeup and Trimming settings and returns the display to the Main Screen.



Selecting [RETURN], returns the display to the Main Screen without altering Makeup or Trimming settings in any way.

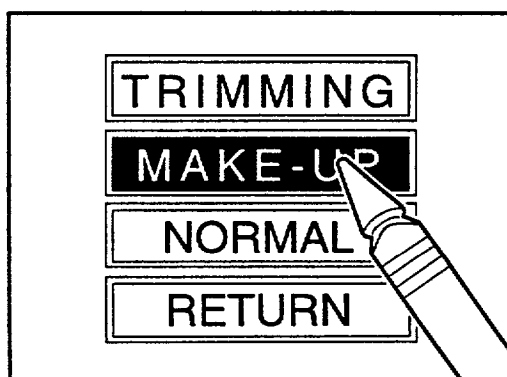

4 Select the mode.

Select from Photograph, Masking, Outline Type*Pattern, Reversing. For demonstration purposes, [PHOTOGRAPH] has been selected here.

The document is scanned.

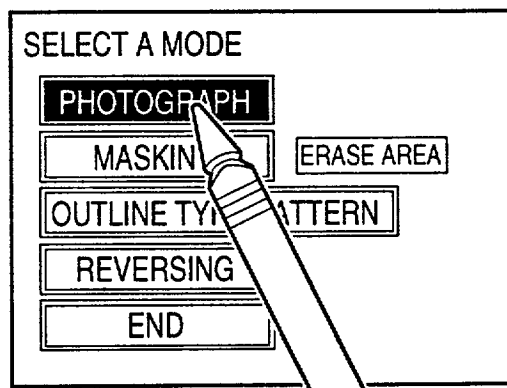

5 Select [ZOOM].

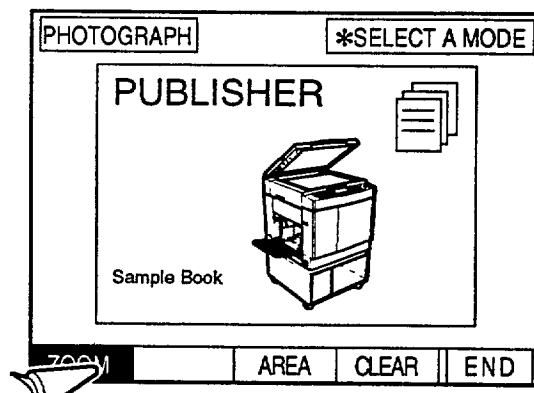

6 Select either [ZOOM2] or [ZOOM3].

Here we have selected [ZOOM2].

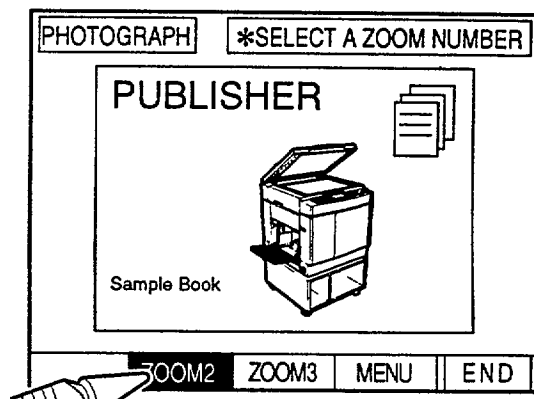

7 Touch the pen to the LCD Panel in the center of the area you wish to enlarge.

The specified area will be enlarged. If you want to switch to [ZOOM1] or [ZOOM3], select [ZOOM] and repeat Step 6.

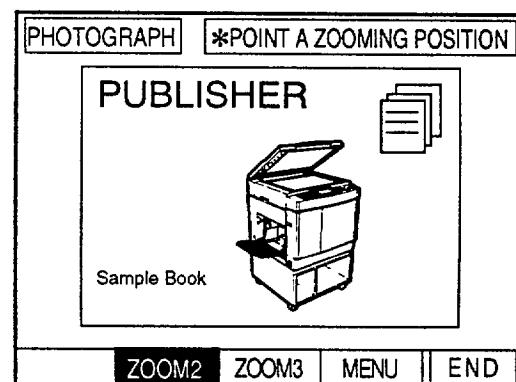

When checking out enlarged areas of a document in the Zoom mode, you can move to those parts of the document you want to view by simply sliding the input pen across the LCD Panel. This form of movement does not work in the Zoom 1 mode. For more details concerning the Move function, see the section "Moving" in Chapter 5.

Moving

Function

When checking out enlarged areas of a document in the Zoom mode, you can move to those parts of the document you want to view by simply sliding the input pen across the LCD Panel.

Operation

1 Perform Steps 1 through 7 of the Zoom function described on the preceding pages.

2 Select [MOVE].

A [+] will appear on the LCD Panel.

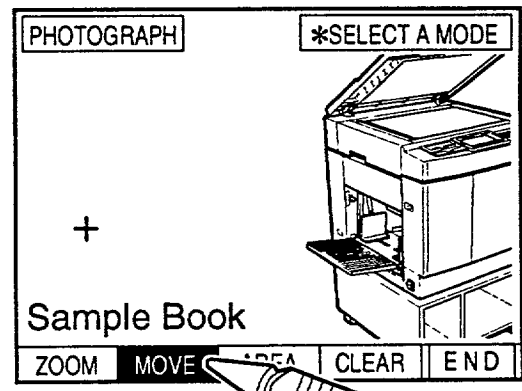

3 Touch the pen to the center of the [+].

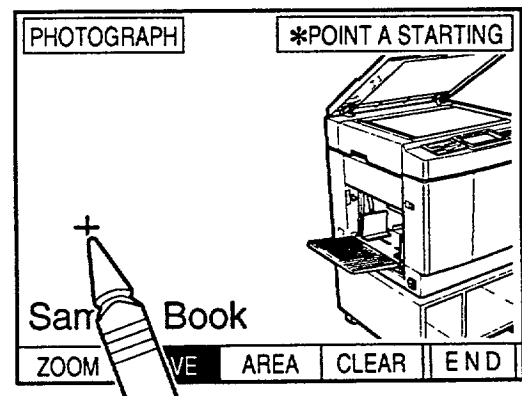

4 Keeping the pen pressed gently against the LCD Panel, move it in the direction of the location you wish to view.



If you touch the pen to the LCD Panel at a location other than the [+], that spot becomes the center of the screen.

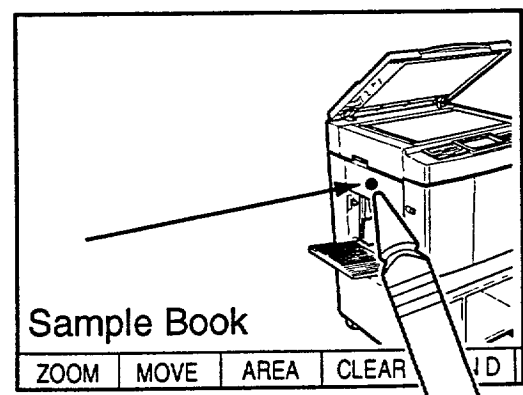

5 When that part of the document you want to view appears, remove the pen from the LCD Panel.

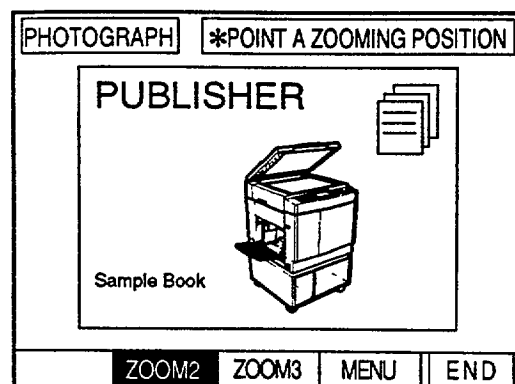

6 Select [MOVE].
The [+] disappears.

Tip To specify an area, select [AREA].

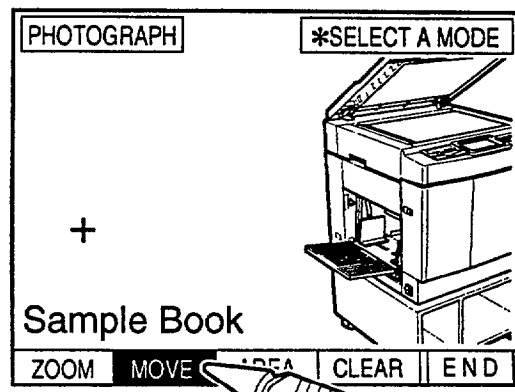

Makeup

Makeup Functions

Allows you to perform the following processes on specified portions of a document.

- Photograph Mode

Allows you to make plates in the Photograph Mode for specified portions of a document. Plates possessing suitable contrast can be made for the photograph portions of documents that consist of a mixture of text and photographs.

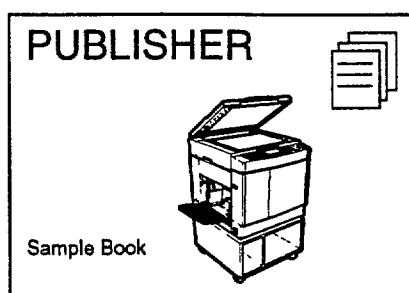

- **Masking Mode**

Allows you to mask those portions of a document that you do not need prior to printing.

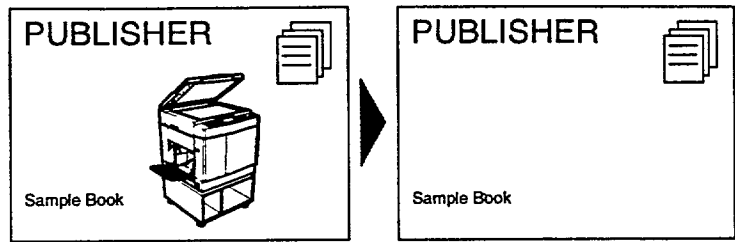

- **Outline Type*Pattern Modes**

- **Outline Type Mode**

Outline Type can be created in specified portions of a document. This mode is convenient when you want to make a title or product name stand out.

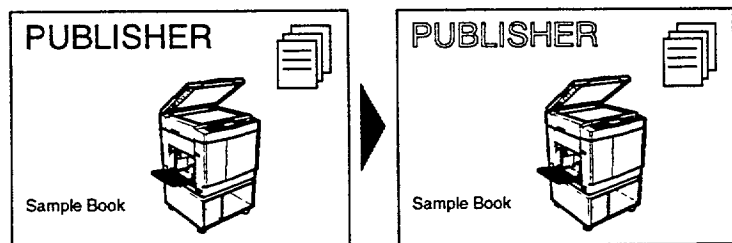

- **Pattern Mode**

Allows you to select from among 20 patterns, to include mesh and background patterns, for insertion in a document. These patterns can be used as backgrounds for illustrations and text.

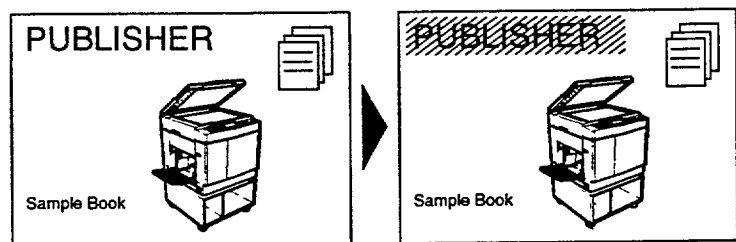

● Reversing Mode

Allows you to display specified portions of a document in reverse video, enabling you to highlight headlines and other titles.

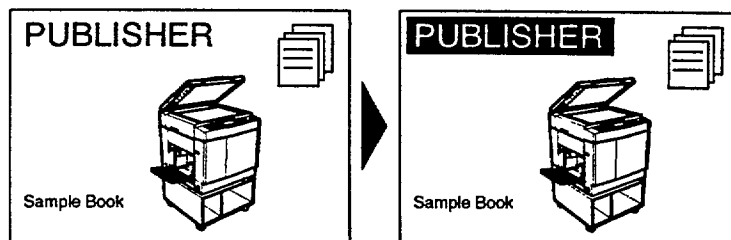

IMPORTANT

- Each mode has its own priority. When a portion of an area overlaps with another mode, the mode with the highest priority takes precedence. In order of priority, these modes are: 1. Masking 2. Reversing 3. Photograph 4. Outline Type*Pattern (The lower the number, the higher the priority.)
- The Main Screen Text/Photograph Mode settings are ignored during Makeup.

Photograph Mode (Making Plates for Photographs)

Function

When a text document contains a photograph, this mode enables the production of a clear plate by allowing you to specify only the photograph portion of the document in the Photograph Mode.

Operation

1 Make sure the Main Screen is displayed.

2 Select [EDIT].

The printer scans the document and displays the Editing Monitor Screen.

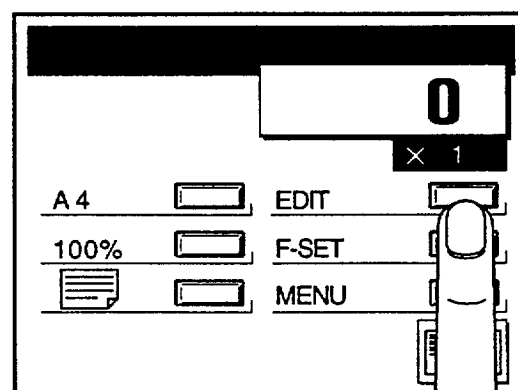

3 Select [MAKE-UP].

Selecting [NORMAL] clears Makeup and Trimming settings and returns the display to the Main Screen.

Tip

Selecting [RETURN], returns the display to the Main Screen without altering Makeup or Trimming settings in any way.

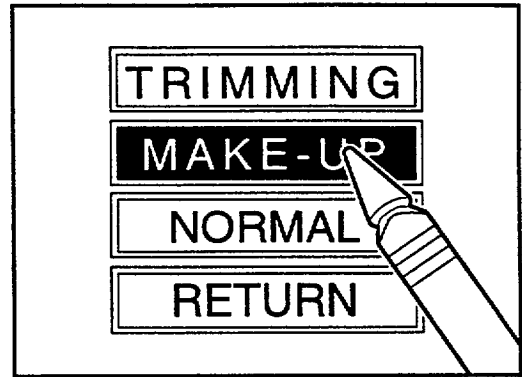

4 Select [PHOTOGRAPH].

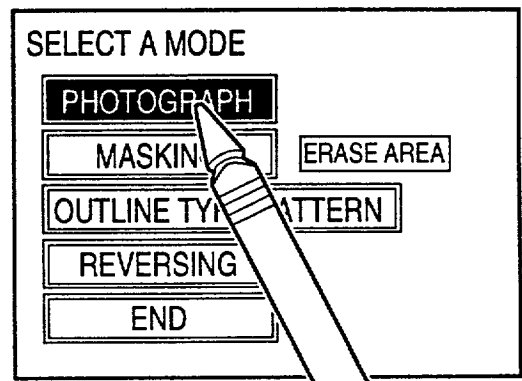

5 Select [AREA].

To enlarge an area of the document, select [ZOOM] at this time. This enables you to zoom in on that portion of the document you are interested in, facilitating your specification of an Editing Area. For more details, see the Section "Zoom/Move" in Chapter 5.

Tip

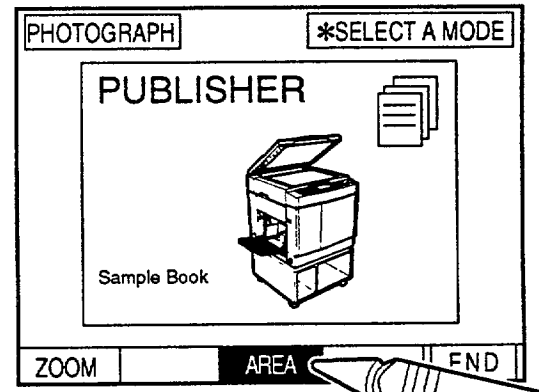

6 Select an area specification method.

You can choose from among the "Rectangle," "Polygon" and "Paint" specification methods. For demonstration purposes, we have selected the "Rectangle" method here. For more details, see the Section "Pen Input" in Chapter 5.

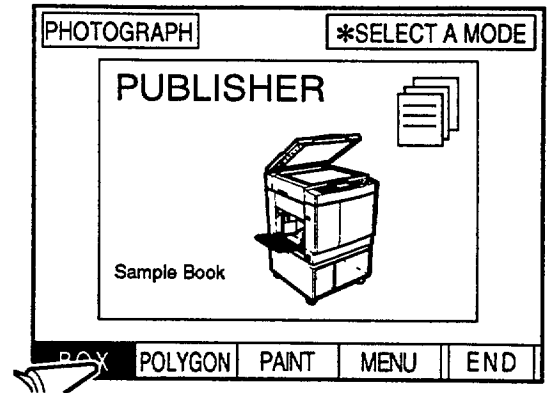

7 Specify an area.

Gently touch the pen to the LCD Panel at that point where you want to start specifying the Editing Area. Here, for demonstration purposes, we will make a plate using the illustration in the example document as a photograph.

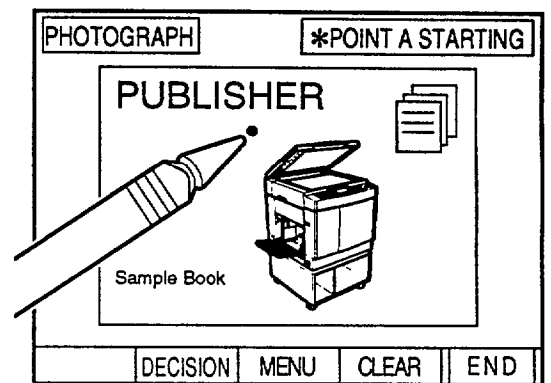

8 The rectangular area is created by moving the pen diagonally away from the starting point, making sure to keep it in contact with the LCD Panel.

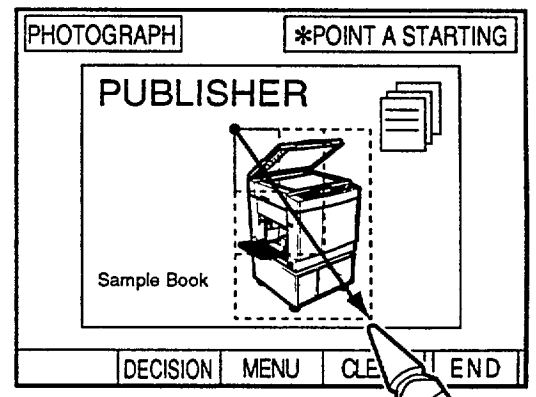

9 Remove the pen from the LCD Panel.

The Editing Area is specified.

Tip To re-specify the area, repeat Steps 7 through 9.

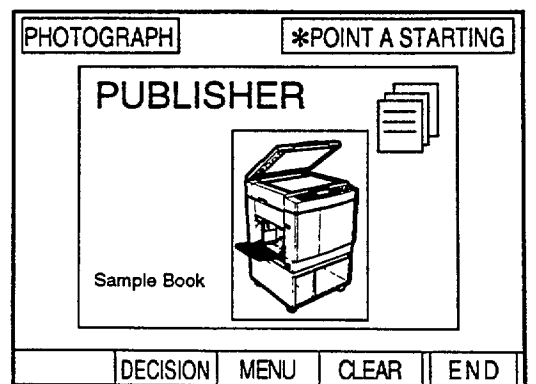

10 If the area you have specified is satisfactory, select [DECISION].

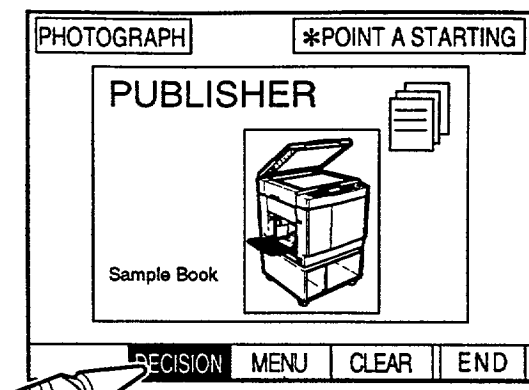

11 Touch the pen to the area (either inside or outside of the rectangle) for which you want to make a plate using the Photograph Mode.

Tip Touching the pen outside the rectangular area causes the entire area outside the rectangle to be made up in the current mode.

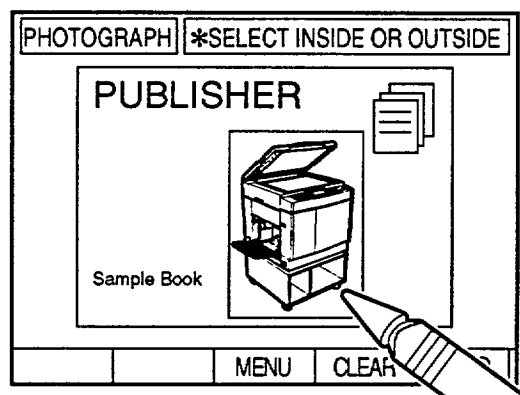

IMPORTANT

- When a portion of an area overlaps with another mode, the mode with the highest priority takes precedence.
- In order of priority, these modes are: 1. Masking 2. Reversing 3. Photograph 4. Outline Type*Pattern

12 Select [END].

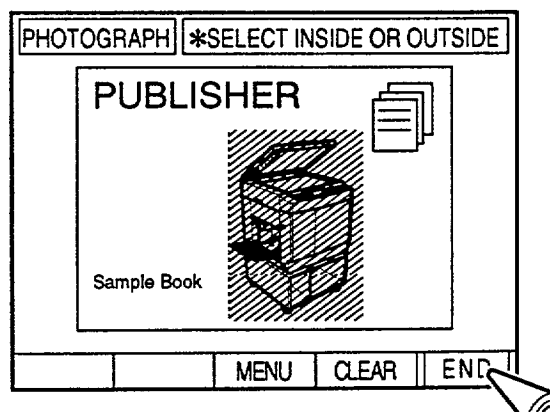

To cancel an area specification, select [Cancel]. Selecting [Cancel] changes the display as shown below.



- If you select [ALL CL], the entire area specified will be canceled.
- If you select [PEN CL], only those portions of the area touched by the pen will be canceled.
- Selecting [Area] returns the display to the Pen Input Specification Screen.

13 Select [END].

The display returns to the Main Screen.

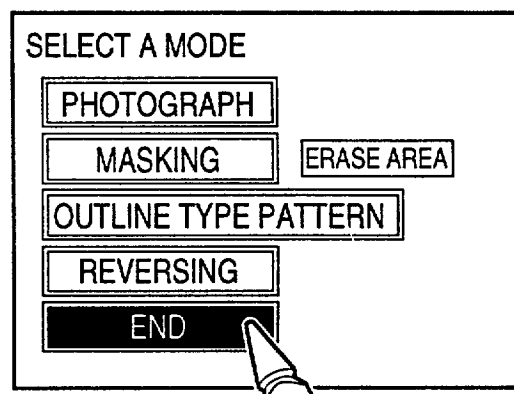

Masking Mode (Deletes Part of a Document)

Function

Allows you to delete unnecessary portions of a document.

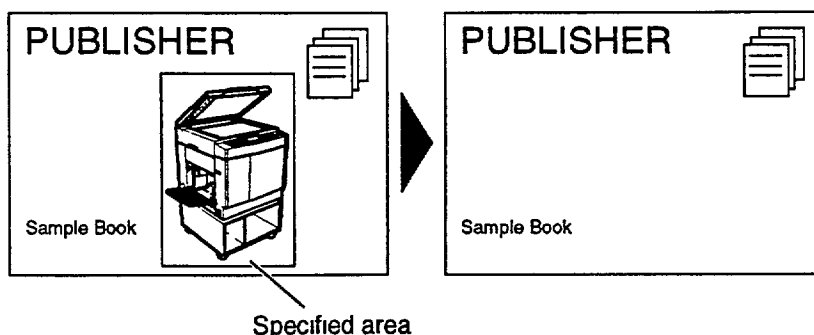

- You can make the area you want to delete easier to see by causing it to flash on and off.
- The Delete Mode can be used with color printing operations, too. Prepare the first plate, then delete the second plate prior to printing the first. Next, carry out the desired color printing by switching the deleted area and printing the second plate.
- See the Section "Switching the Delete Area" in Chapter 5.

Tip

III Operation

1 Make sure the Main Screen is displayed.

2 Select [EDIT]

The printer scans the document and displays the Editing Monitor Screen.

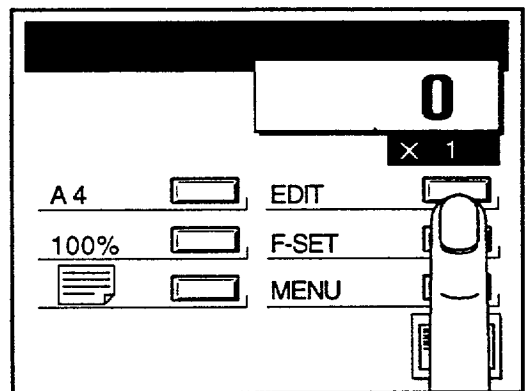

3 Select [MAKE-UP].

Selecting [NORMAL] clears Makeup and Trimming settings and returns the display to the Main Screen.

Selecting [RETURN], returns the display to the Main Screen without altering Makeup or Trimming settings in any way.

Tip

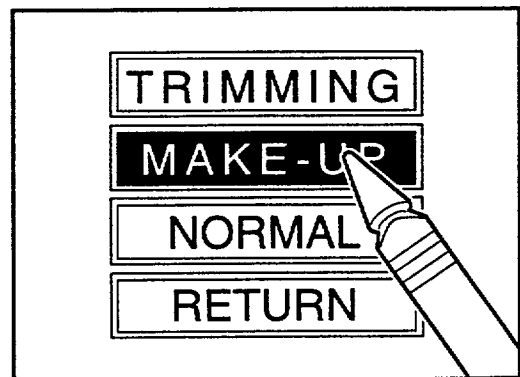

4 Select the Delete Mode Area Screen.

The Delete Mode Area consists of [Erase Area] and [Blink Area].

- Erase Area: Deletes the specified area prior to displaying the screen.
- Blink Area: Causes the specified area to flash on and off.

For demonstration purposes, here we have selected [BlinkArea].

Tip

Touching the pen to [BLINK AREA] changes it to [ERASE AREA], and touching the pen to [DELETE AREA] changes it to [BLINK AREA].

5 Select [MASKING].

6 Select [AREA].

Tip

To enlarge an area of the document, select [ZOOM] at this time. This enables you to zoom in on that portion of the document you are interested in, facilitating your specification of an Editing Area. For more details, see the Section "Zoom/Move" in Chapter 5.

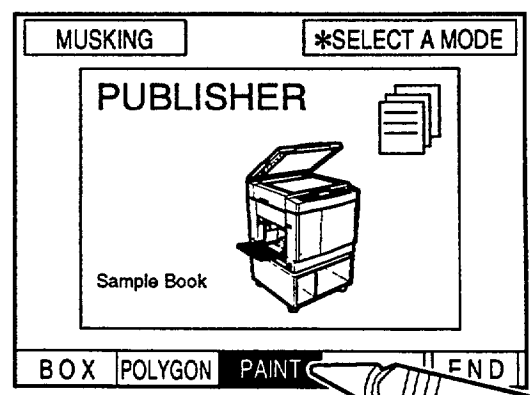
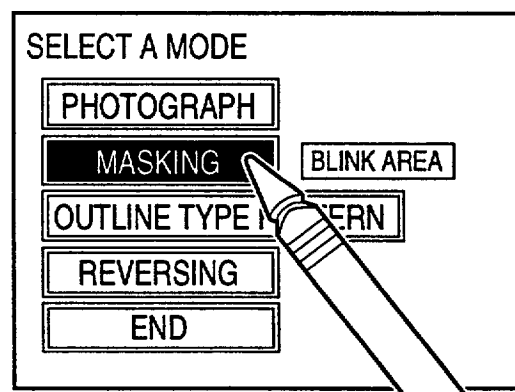
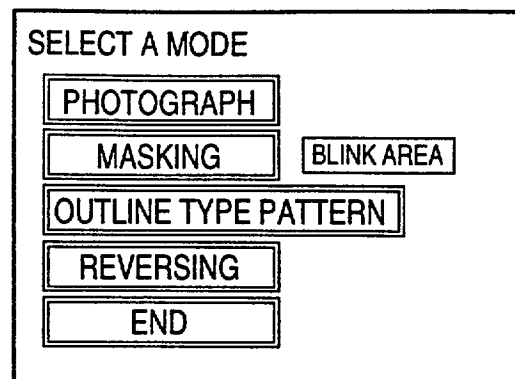

7 Select the area specification method.

You can choose from among the "Box" "Polygon" and "Paint" specification methods. For demonstration purposes, we have selected the "Box" method here. For more details, see the Section "Pen Input" in Chapter 5.

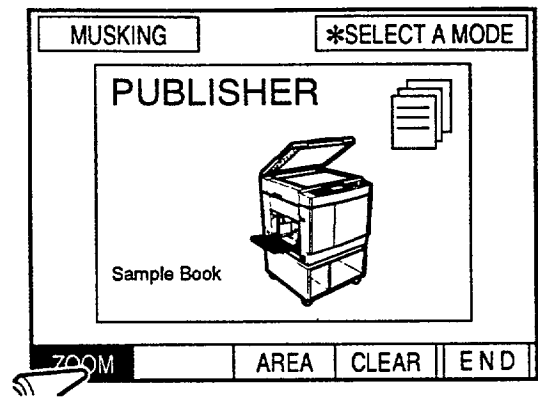

8 Specify an area.

Gently touch the pen to the LCD Panel at that point where you want to start specifying the Editing Area. Here, for demonstration purposes, the illustration portion of the example document is specified for deletion.

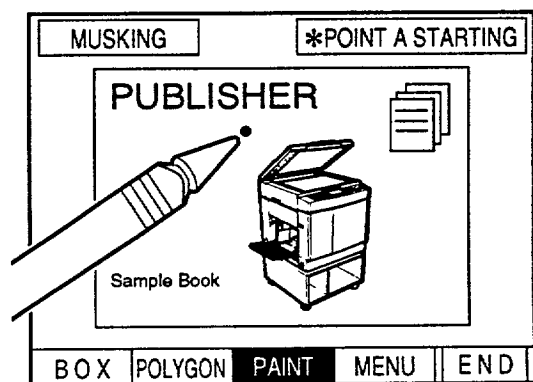

9 The rectangular area is created by moving the pen diagonally away from the starting point, making sure to keep it in contact with the LCD Panel.

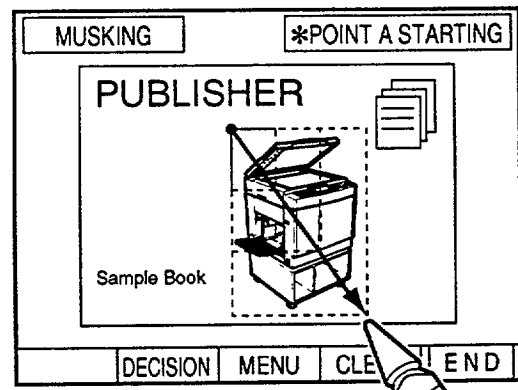

10 Remove the pen from the LCD Panel.

The Editing Area is specified.

Tip To re-specify the area, repeat Steps 7 through 9.

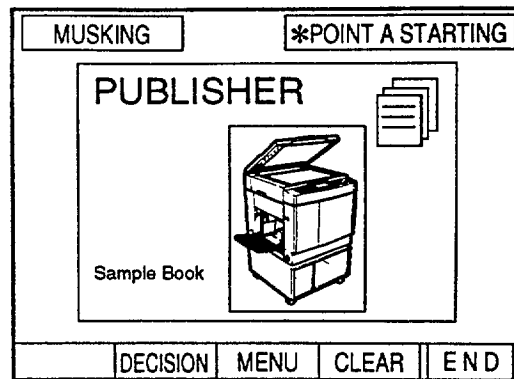

11 If the area you have specified is satisfactory, select [DECISION].

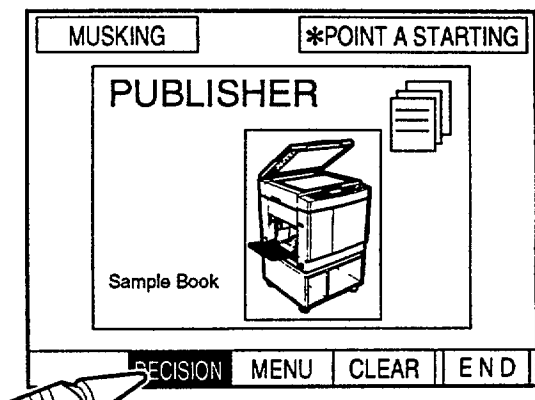

12 Touch the pen to the area (either inside or outside of the rectangle) you want to delete.

Tip

- Touching the pen outside the rectangular area causes the entire area outside the rectangle to be made up in the current mode.
- If you selected [ERASE AREA] in Step 4, the area inside the rectangle disappears from the LCD Panel.

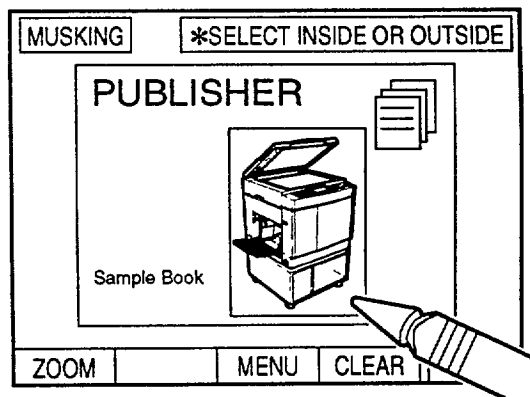

IMPORTANT

- When a portion of an area overlaps with another mode, the mode with the highest priority takes precedence.
- In order of priority, these modes are: 1. Masking 2. Reversing 3. Photograph 4. Outline Type*Pattern

13 Select [END].

To cancel an area specification, select [Cancel]. Selecting [Cancel] changes the display as shown below.

- If you select [ALL CL], the entire area specified will be canceled.
- If you select [PEN CL], only those portions of the area touched by the pen will be canceled.
- Selecting [Area] returns the display to the Pen Input Specification Screen.

Tip

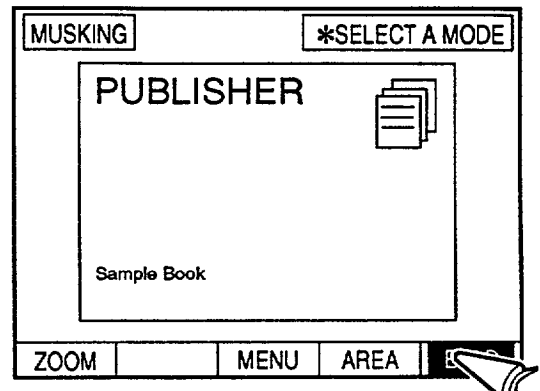

14 Select [END].

The display returns to the Main Screen.

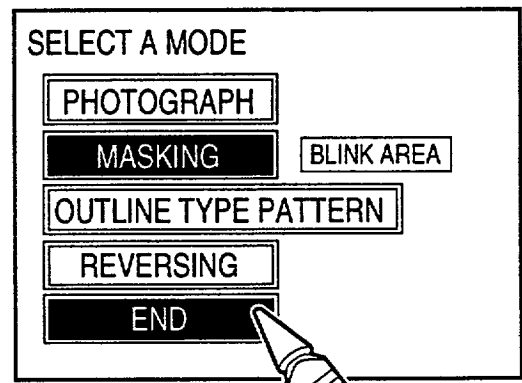

Outline Type (Changes Ordinary Text to Outline Type) And Patterns (Inserts Designs)

Function

Outline Type Mode

Allows you to change the text inside a specified area of a document to Outline Type. This function can be used to effectively highlight titles and product names. Select Pattern No. 21.

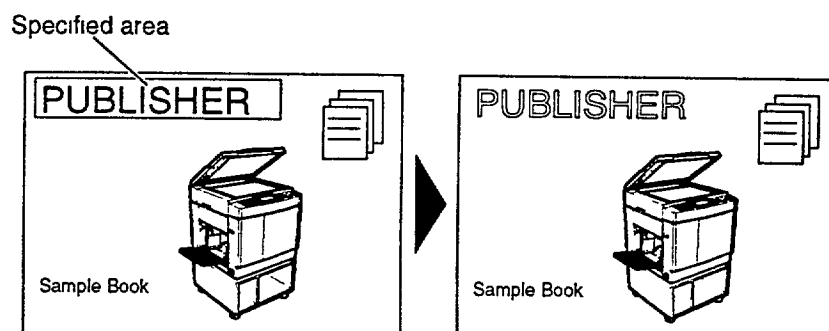

Pattern Mode

Allows you to insert mesh or background designs into specified areas of a document. You can select from among 20 different mesh and background patterns.

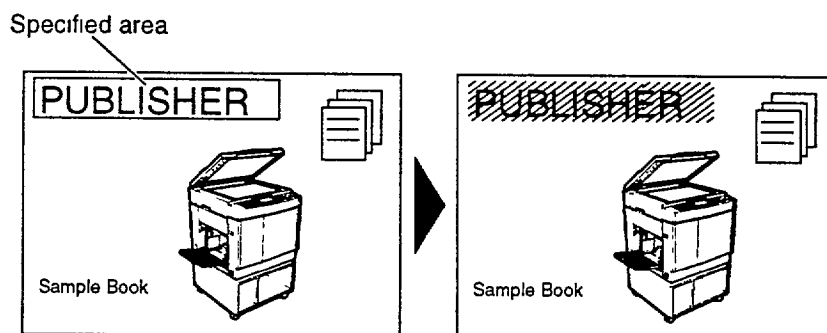

Operation

1 Make sure the Main Screen is displayed.

2 Select [EDIT]

The printer scans the document and displays the Editing Monitor Screen.

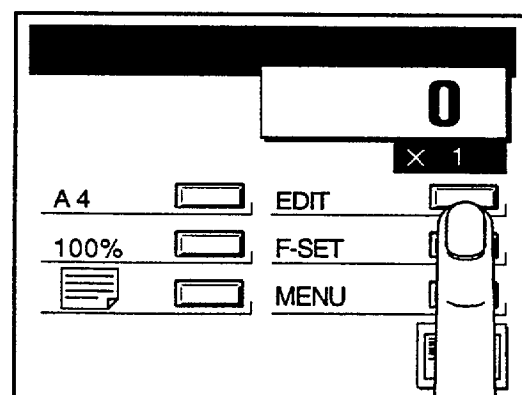

3 Select [MAKE-UP].

Selecting [NORMAL] clears Makeup and Trimming settings and returns the display to the Main Screen.

Tip

Selecting [RETURN], returns the display to the Main Screen without altering Makeup or Trimming settings in any way.

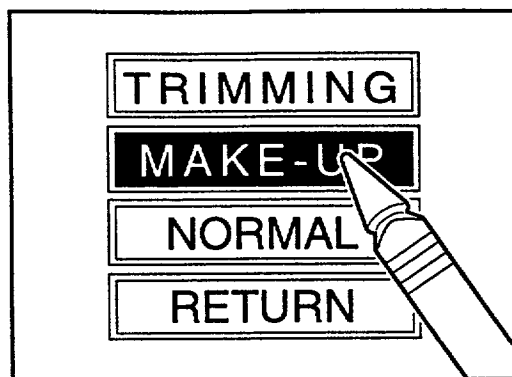

4 Select [OUTLINE TYPE*PATTERN].

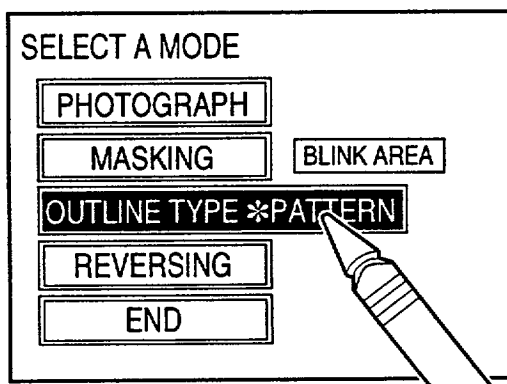

5 Use the or keys to select outline type or a pattern.

To specify outline type, select No. 21. To specify a Pattern, choose from among those designs numbered 01 through 20.

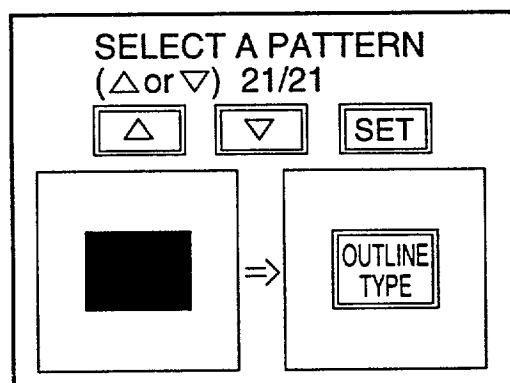

no	PATTERN	01		02		03		04		05		06	
07		08		09		10		11		12		13	
14		15		16		17		18		19		20	

6 Select [SET].

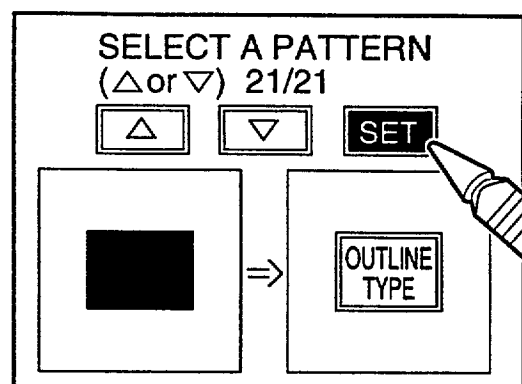

7 Select [AREA]



To enlarge an area of the document, select [ZOOM] at this time. This enables you to zoom in on that portion of the document you are interested in, facilitating your specification of an Editing Area. For more details, see the Section "Zoom/Move" in Chapter 5.

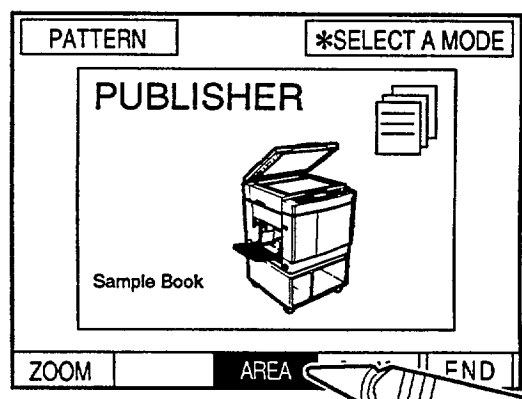

8 Select the area specification method.

You can choose from among the "Box" "Polygon" and "Paint" specification methods. For demonstration purposes, we have selected the "Box" method here. For more details, see the Section "Pen Input" in Chapter 5.

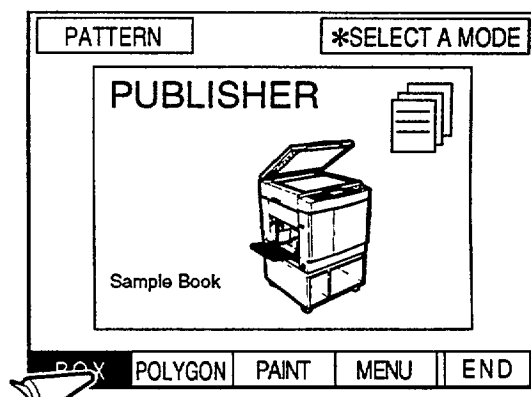

9 Specify an area.

Gently touch the pen to the LCD Panel at that point where you want to start specifying the Editing Area. Here, for demonstration purposes, "PUBLISHER" is specified as the area where a pattern will be inserted.

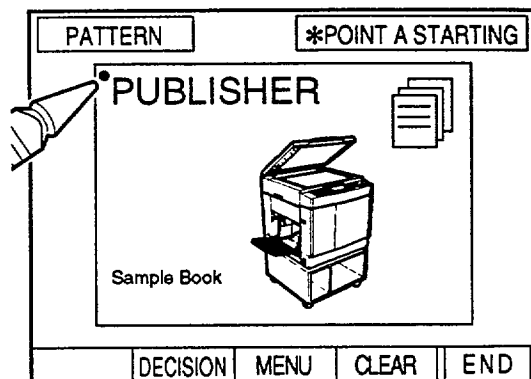

10 The rectangular area is created by moving the pen diagonally away from the starting point, making sure to keep it in contact with the LCD Panel.

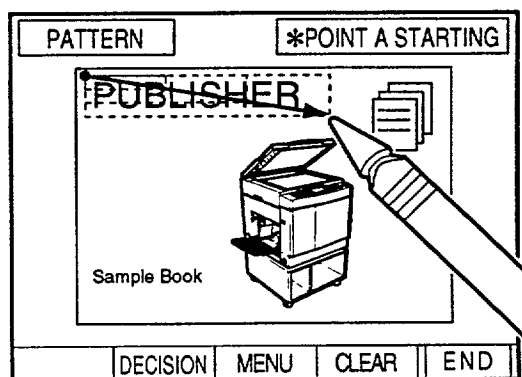

11 Remove the pen from the LCD Panel.

The Editing Area is specified.

Tip

To re-specify the area, repeat Steps 7 through 9.

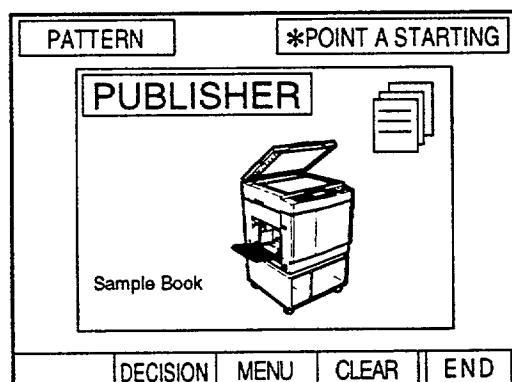

12 If the area you have specified is satisfactory, select [DECISION].

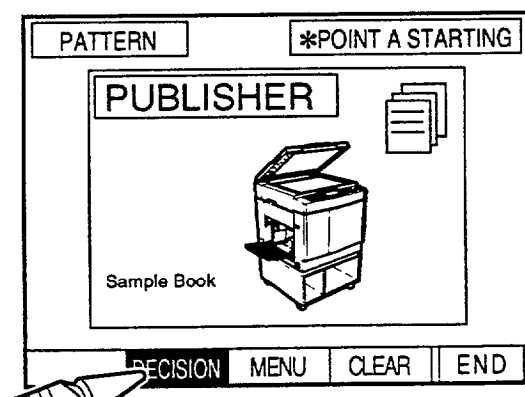

13 Touch the pen to the area inside the rectangle.

Tip Touching the pen outside the rectangular area causes the entire area outside the rectangle to be made up in the current mode.

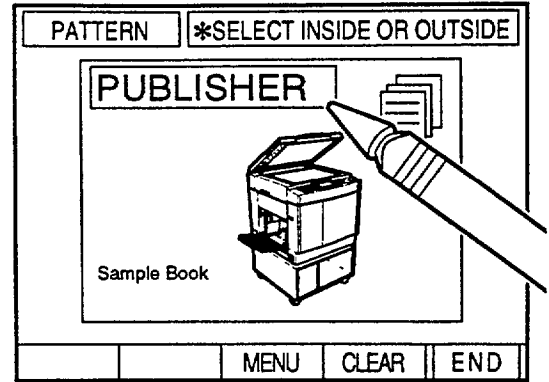

IMPORTANT

- When a portion of an area overlaps with another mode, the mode with the highest priority takes precedence.
- In order of priority, these modes are: 1. Masking 2. Reversing 3. Photograph 4. Outline Type*Pattern

14 Select [END].

To cancel an area specification, select [Cancel]. Selecting [Cancel] changes the display as shown below.

- If you select [ALL CL], the entire area specified will be canceled.
- If you select [PEN CL], only those portions of the area touched by the pen will be canceled.
- Selecting [Area] returns the display to the Pen Input Specification Screen.

Tip

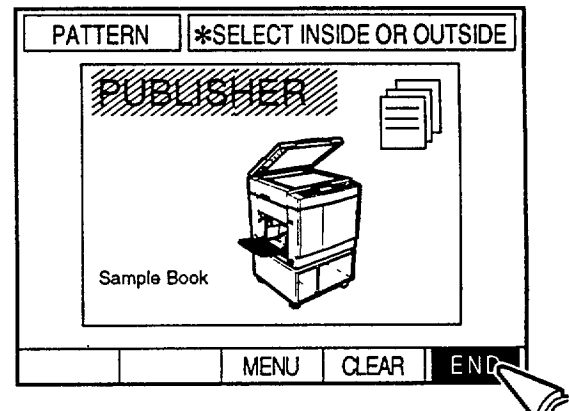

15 Select [END].

The display returns to the Main Screen.

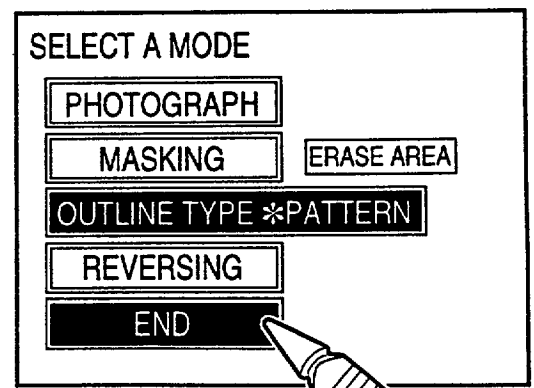

Reversing Mode (Reverses The Video (Monochrome) on a Portion of a Document)

Function

Allows you to reverse the video (from black-on-white to white-on-black) at a specified area on a document.

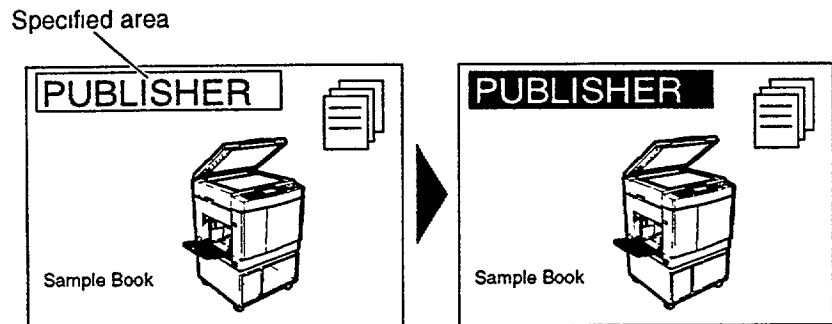

Operation

1 Make sure the Main Screen is displayed.

2 Select [EDIT].

The Editing Monitor Screen is displayed.

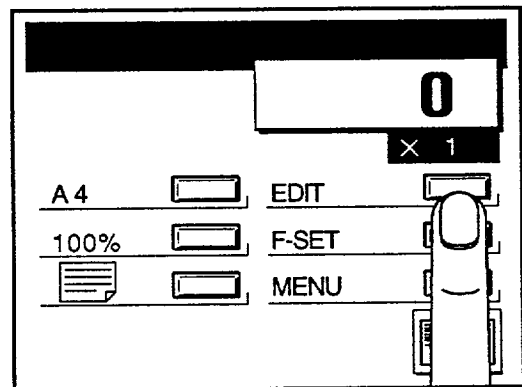

3 Select [MAKE-UP].

Selecting [NORMAL] clears Makeup and Trimming settings and returns the display to the Main Screen.



Selecting [RETURN], returns the display to the Main Screen without altering Makeup or Trimming settings in any way.

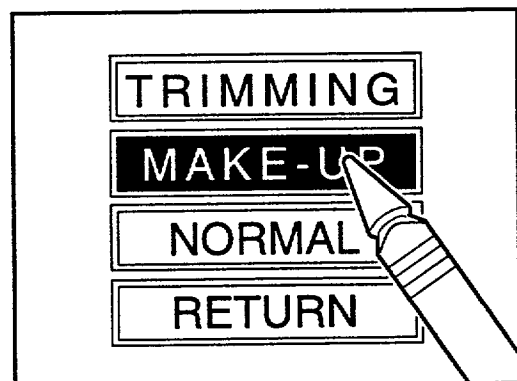

4 Select [REVERSING].

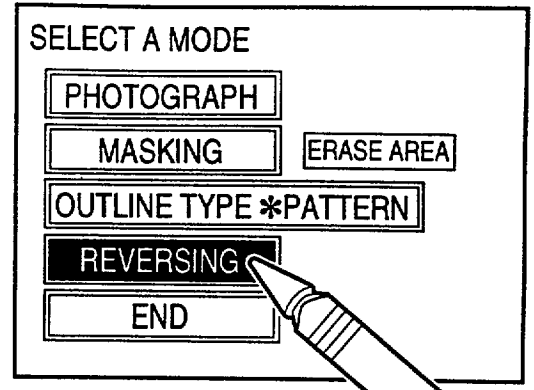

5 Select [AREA]

To enlarge an area of the document, select [ZOOM] at this time. This enables you to zoom in on that portion of the document you are interested in, facilitating your specification of an Editing Area. For more details, see the Section "Zoom/Move" in Chapter 5.

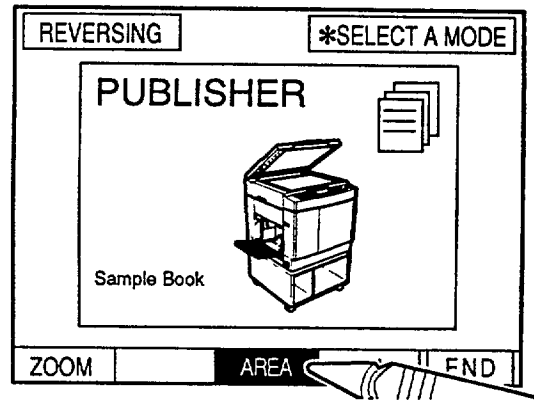

6 Select the area specification method.

You can choose from among the "Box", "Polygon" and "Paint" specification methods. For demonstration purposes, we have selected the "Box" method here. For more details, see the Section "Pen Input" in Chapter 5.

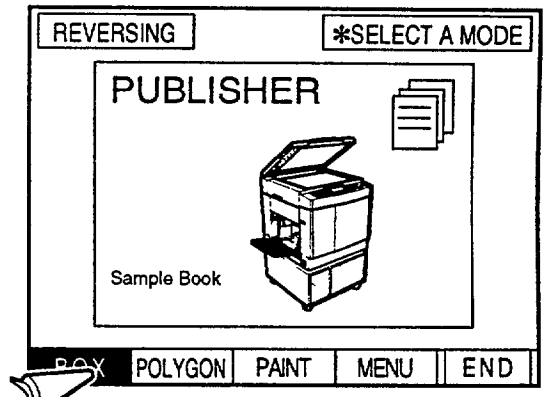

7 Specify an area.

Gently touch the pen to the LCD Panel at that point where you want to start specifying the Editing Area. Here, for demonstration purposes, "PUBLISHER" is specified as the Reverse Video area.

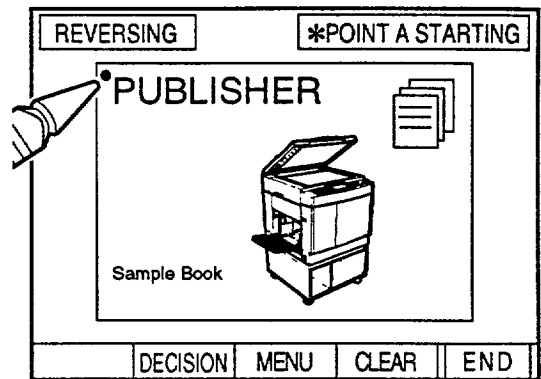

8 The rectangular area is created by moving the pen diagonally away from the starting point, making sure to keep it in contact with the LCD Panel.

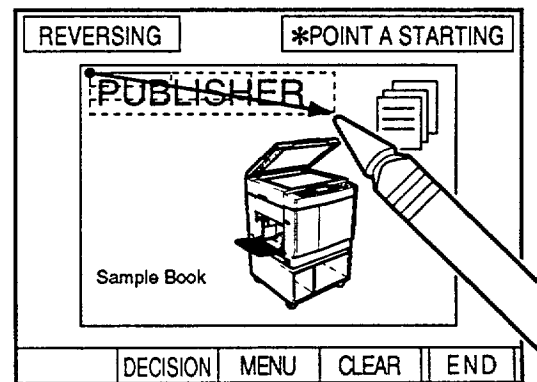

9 Remove the pen from the LCD Panel.

The Editing Area is specified.

Tip To re-specify the area, repeat Steps 7 through 9.

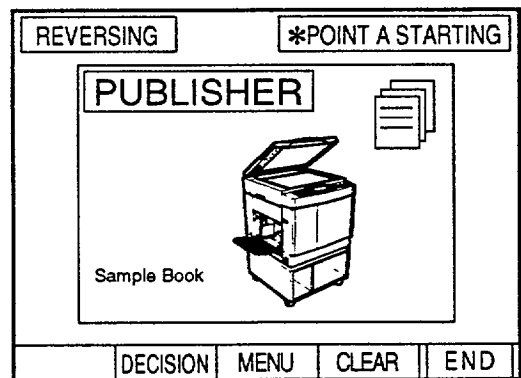

10 If the area you have specified is satisfactory, select [DECISION].

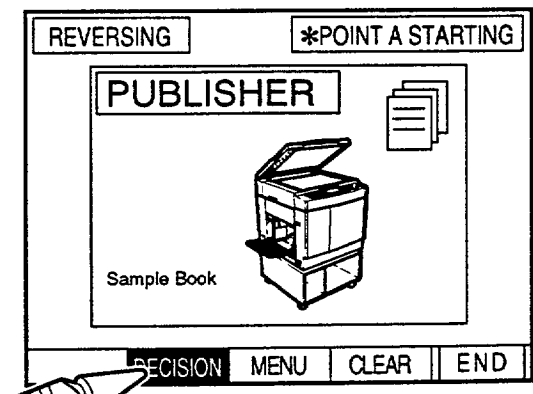

11 Touch the pen inside the area to be displayed in Reverse Video.

Tip Touching the pen outside the rectangular area causes the entire area outside the rectangle to be made up in the current mode.

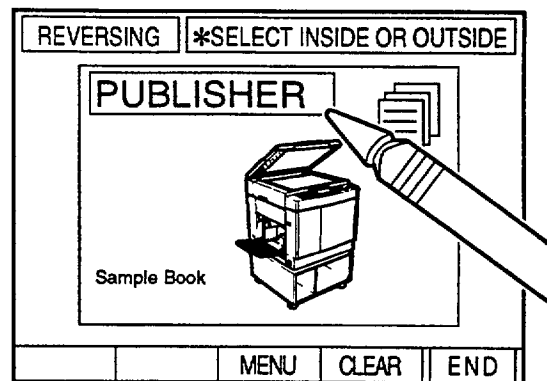

IMPORTANT

- When a portion of an area overlaps with another mode, the mode with the highest priority takes precedence.
- In order of priority, these modes are: 1. Masking 2. Reversing 3. Photograph 4. Outline Type*Pattern

12 Select [END].

To cancel an area specification, select [Cancel]. Selecting [Cancel] changes the display as shown below.

- If you select [ALL CL], the entire area specified will be canceled.
- If you select [PEN CL], only those portions of the area touched by the pen will be canceled.
- Selecting [Area] returns the display to the Pen Input Specification Screen.

Tip

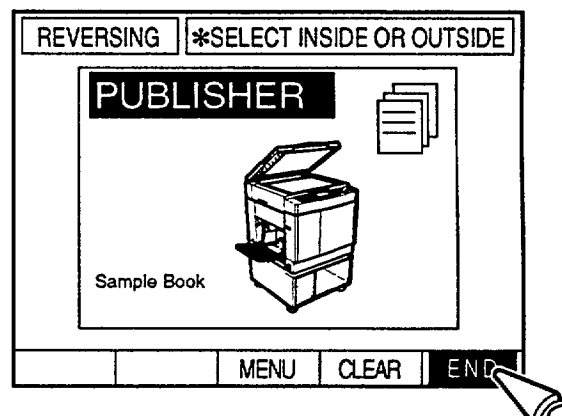

13 Select [END].

The display returns to the Main Screen.

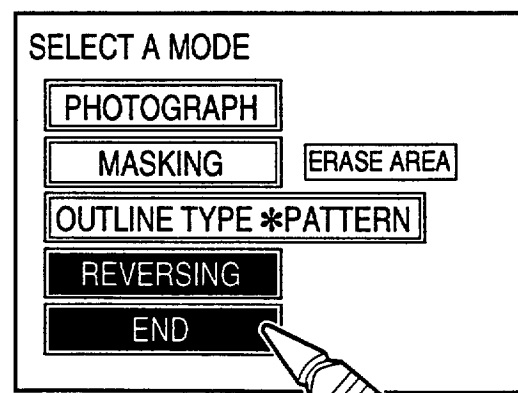

Adding Makeup

Function

Allows you to add Makeup functions under the following conditions:

- Once Makeup settings have been completed.
- Once Makeup settings have been set, and Platemaking and Printing have been completed.
- When any of the Makeup settings saved under Function Keys F1 through F3 have been called up.
- When any of the Makeup settings saved under Function Keys F1 through F3 have been called up, and Platemaking and Printing have been completed.

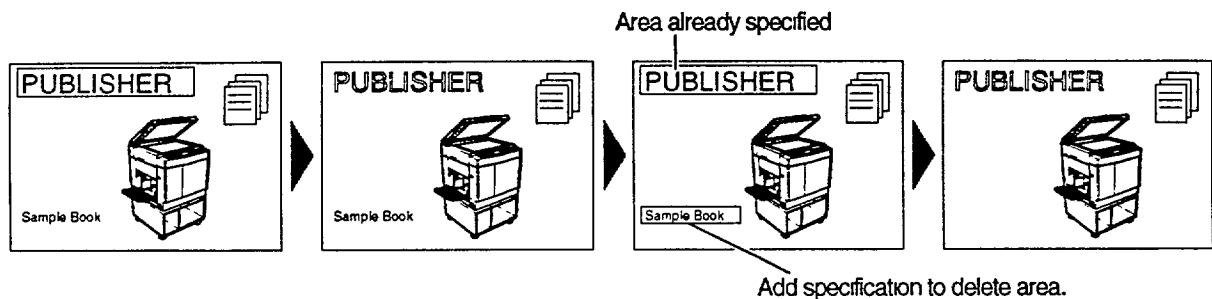

Operation

1 Make sure the Main Screen is displayed.

2 Select [EDIT]

The printer scans the document and displays the Menu Screen.

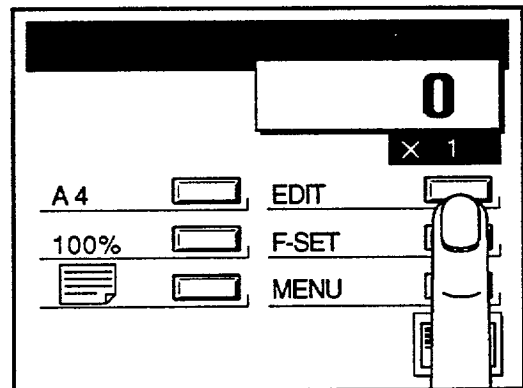

3 Select [MAKE-UP].

Selecting [NORMAL] clears Makeup and Trimming settings and returns the display to the Main Screen.



Selecting [RETURN], returns the display to the Main Screen without altering Makeup or Trimming settings in any way.

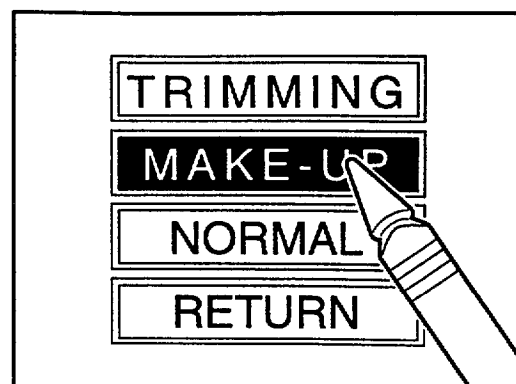

4 Select [ADDITIONAL MAKE-UP]

IMPORTANT

- [ADDITIONAL MAKE-UP] is not displayed unless Makeup has been set in advance.
- [MASK AREA EXCHANGE] is not displayed unless the Delete Mode has been set in advance.

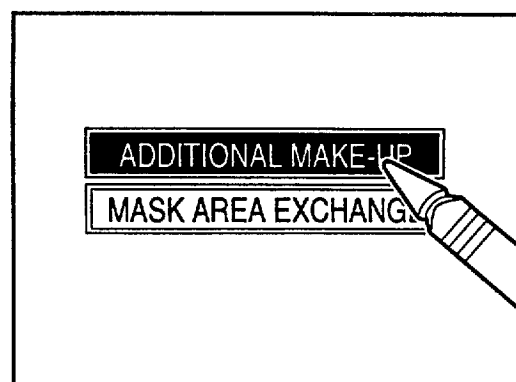

5 Select the mode you want to add, and carry out a Makeup operation.

Switching the Masking Area

Function

Allows you, under the following conditions, to switch the area specified using the Makeup Masking Mode with the surrounding portion of the document (area outside specified area) so that Platemaking and Printing can be carried out for both areas.

- Once Makeup settings have been completed.
- Once Makeup settings have been set, and Platemaking and Printing have been completed.
- When any of the Makeup settings saved under Function Keys F1 through F3 have been called up.
- When any of the Makeup settings saved under Function Keys F1 through F3 have been called up, and Platemaking and Printing have been completed.

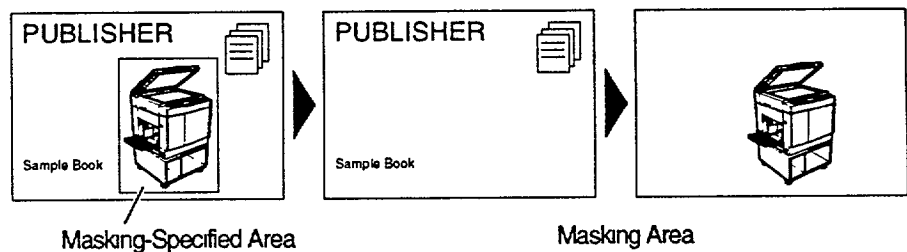

Operation

1 Make sure the Main Screen is displayed.

2 Select [EDIT]

The printer scans the original document and displays the Editing Monitor Screen.

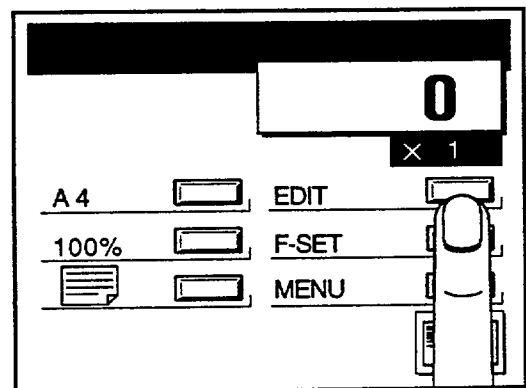

3 Select [MAKE-UP].

Selecting [NORMAL] clears Makeup and Trimming settings and returns the display to the Main Screen.



Selecting [RETURN], returns the display to the Main Screen without altering Makeup or Trimming settings in any way.

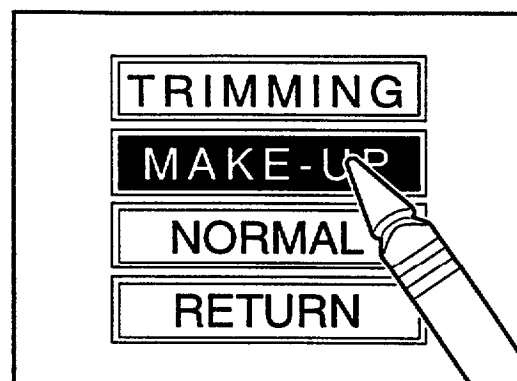

4 Select [MASK AREA EXCHANGE].

IMPORTANT

- [MASK AREA EXCHANGE] is not displayed unless the Masking Mode has been set in advance.

The area specified for masking is switched with the unmasking portion of the document.



Trimming



This function automatically "enlarges" or "reduces" the image of an original document during printing so that it matches up with the size of the paper selected beforehand.

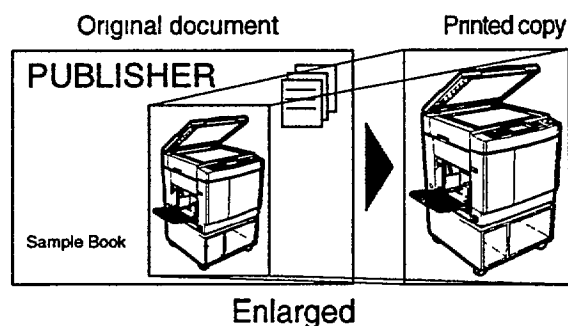

- The Zoom function can be used during a Trimming operation.
- Makeup can be carried out after Trimming.





IMPORTANT

- The enlargement/reduction range extends from 50% to 499%. If you select a paper size or enlargement/reduction ratio that exceeds this range, a  or  will appear to the left of the Enlargement/Reduction display on the LCD Panel and it will not be possible to make accurate copies of the original.

Re-specify the paper size or enlargement/reduction ratio to correspond with the 50% to 499% enlargement/reduction range.

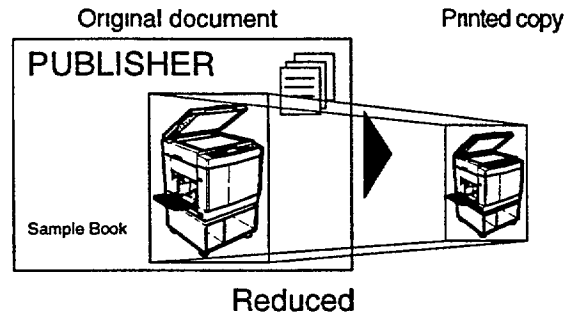
- When the Trimming Mode is ON, the Auto Zoom feature automatically functions. The Trimming function sets the enlargement/reduction ratio on the basis of the size of the paper selected, so always select the correct paper size.



 Reference  Zoom Function

III Operation

1 Make sure the Main Screen is displayed.

2 Select [EDIT]

The printer scans the original document and displays the Editing Monitor Screen.

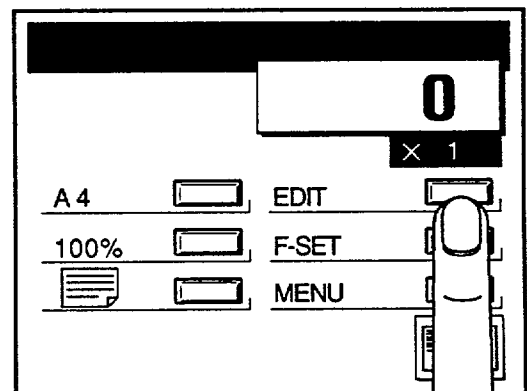

3 Select [TRIMMING].

The printer scans the original document and displays the Trimming Screen on the LCD Panel.

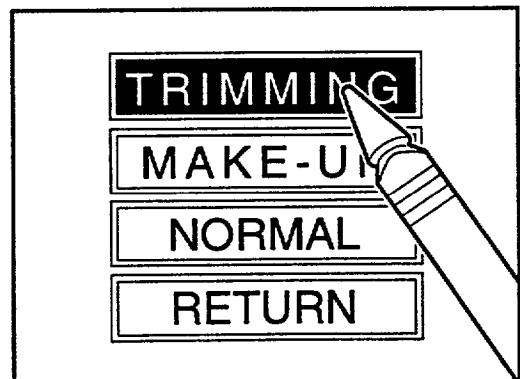

Using the Zoom function enables you to enlarge the display of the area you wish to trim. For more detailed information on the Zoom function, see the section "Zoom Function" in Chapter 5.

Tip

Selecting [NORMAL] clears Makeup and Trimming settings and returns the display to the Main Screen.

Selecting [RETURN], returns the display to the Main Screen without altering Makeup or Trimming settings in any way.

4 Select [AREA].

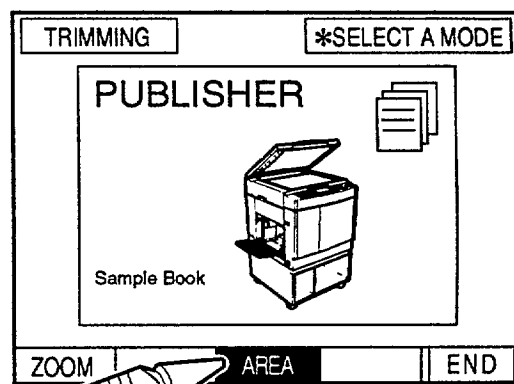

5 Select [DESIGN].

Tip

To specify the entire screen being displayed, select [ALL AREA].

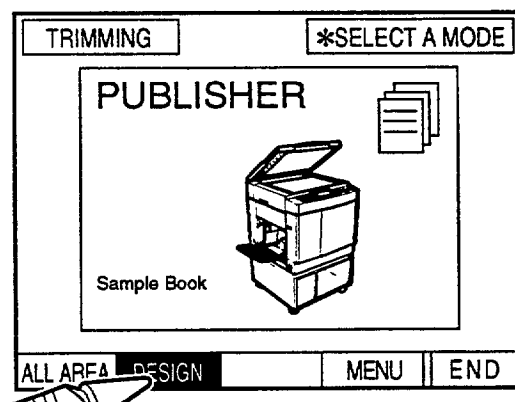

6 Specify the area. Touch the pen lightly to the LCD Panel at that point where you want to start specifying the area to be trimmed.

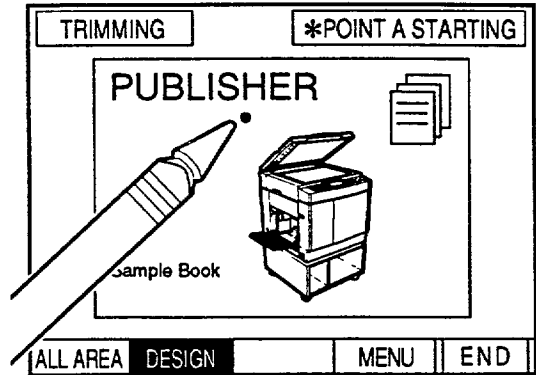

7 Adjust the size of the area by moving the pen across the LCD Panel, keeping the pen in contact with the Panel at all times.

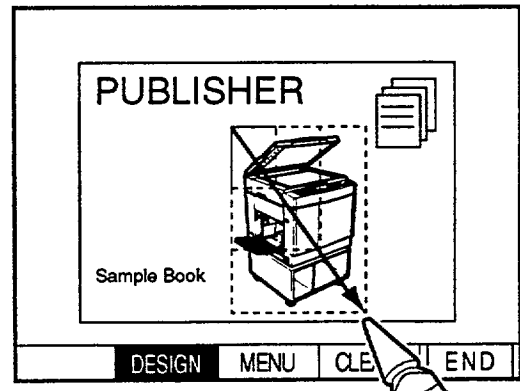

8 Remove the pen from the LCD to establish the final size of the area.

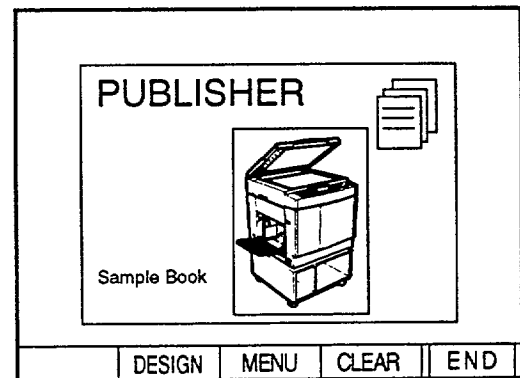

Tip To re-specify the area, repeat Steps 5 through 7.

9 Once the area has been specified, select [DECISION].

This completes the Trimming process. Platemaking can now be carried out.

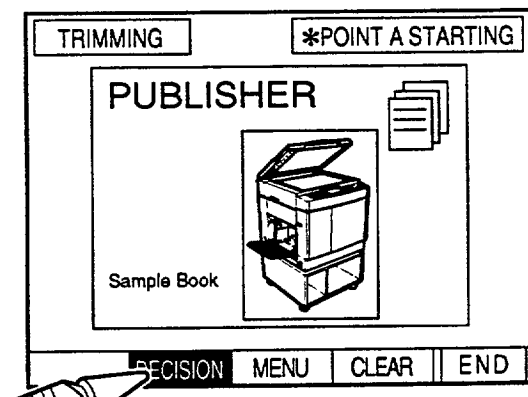

6. Replacing Consumables

Changing the Ink Pack

1 Open the front cover.

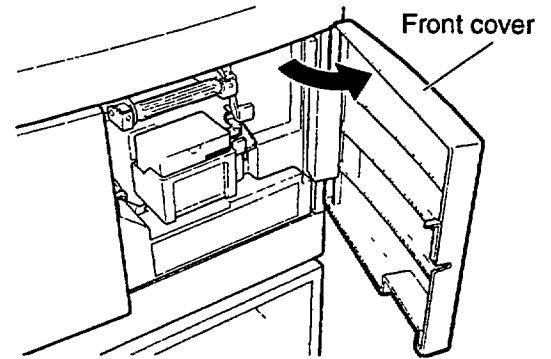

2 Hold the ink pack holder release lever and pull towards you.

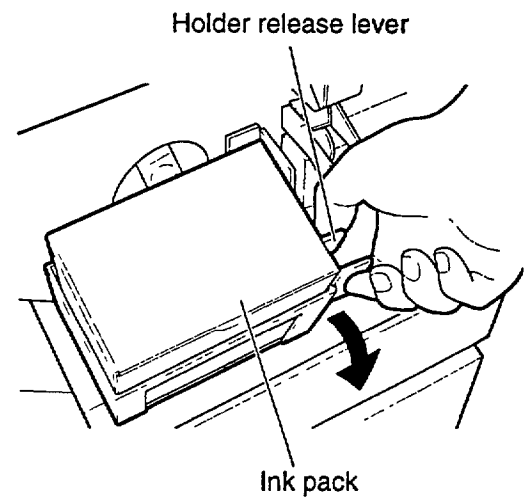

3 Pull up and remove the empty ink pack.



4 Twist open the cap of the new ink pack.

IMPORTANT

- Do not leave an ink pack uncapped for longer than necessary.

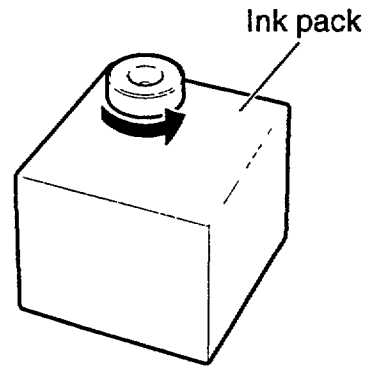

5 Insert the ink pack so that the groove on the lip fits into the "U" groove of the holder.

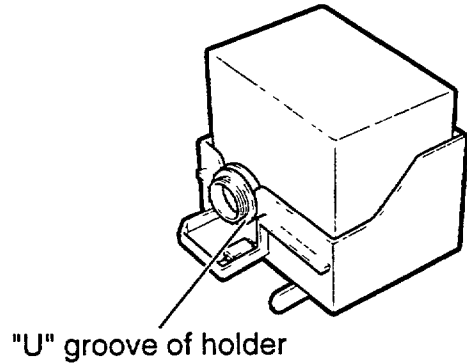
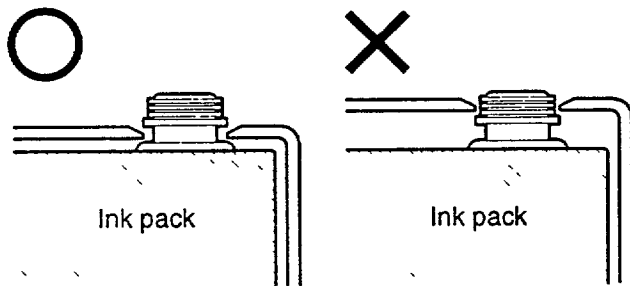

6 Press the ink pack in to the set line on the ink pack.

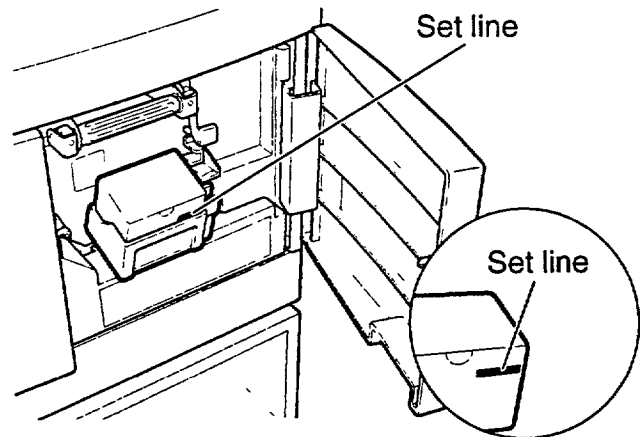

7 Press the side of the holder in with the palm of your hand.

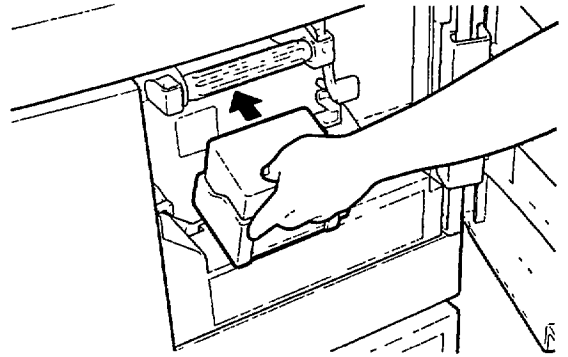

8 Close the front cover.

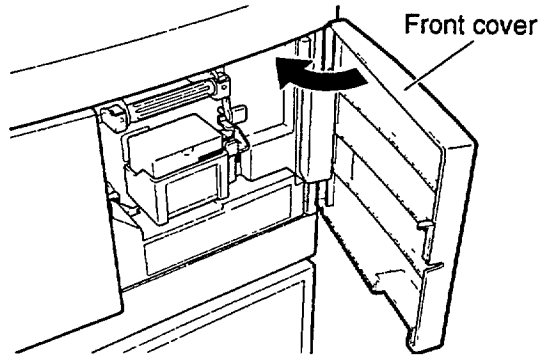

Replacing the Master Roll

1 Raise the top cover release lever.

The top cover will open up.

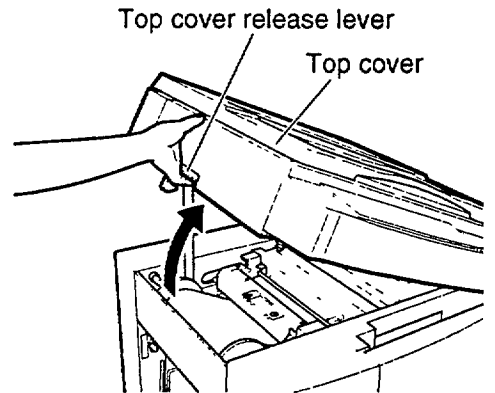

2 Turn the master holder towards you while pressing the head escape lever. Pull out the master.

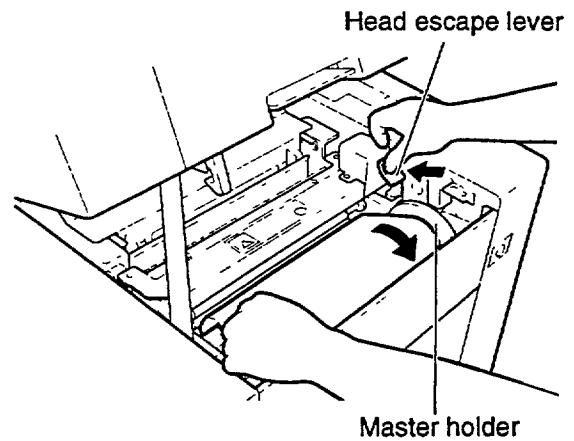

3 Remove the master roll to pull up.

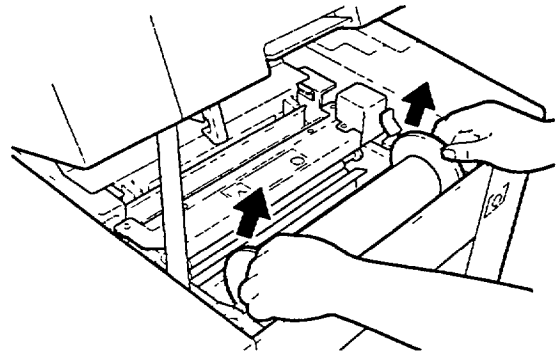

4 Remove the master holder from the master roll.

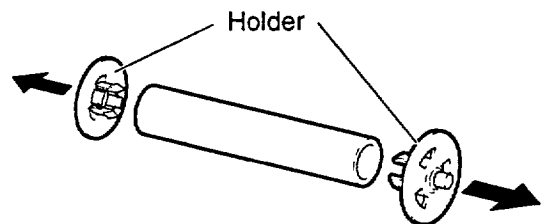

5 Take out a new master roll from the bag.

6 Insert the master holder deeply into both ends of the master roll.

The left and right holders are identical.

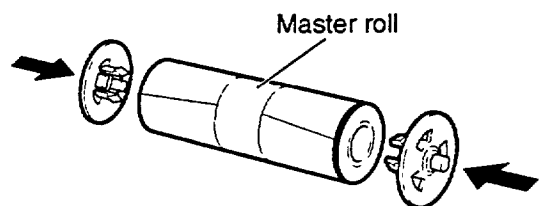

7 Insert the master roll into the machine so that the green line on the roll is facing the control panel.

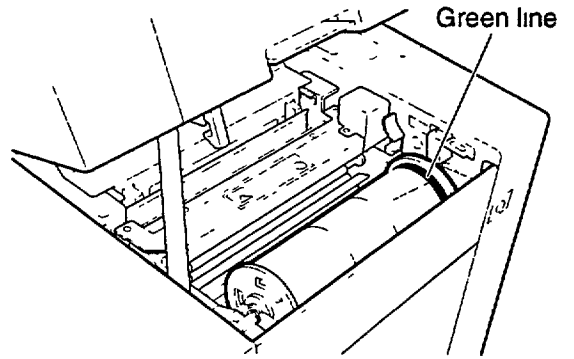

8 Peel off the seal.

IMPORTANT

- Do not peel off the yellow label.

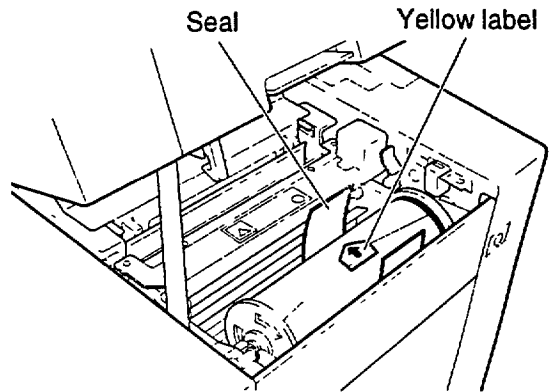

9 Pull out the master and insert the arrow on the yellow label until it contacts the roller.

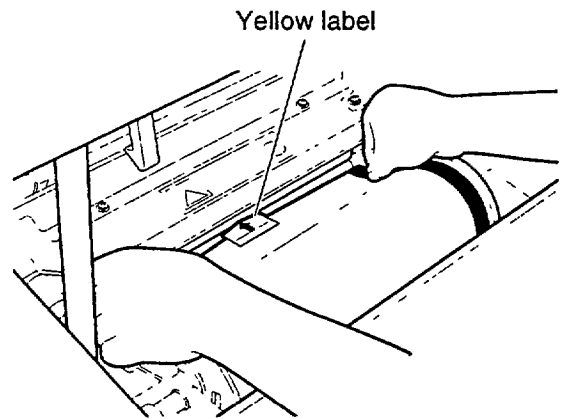

10 Press the master set switch.

The master will be pulled in, and automatically cut.

If the master is not pulled in, press the yellow label lightly toward the back.

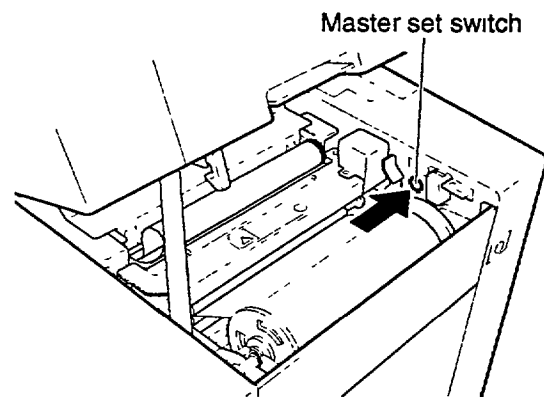

IMPORTANT

- If the master is wrinkled, press the thermal head escape lever a few times while pressing the master set switch.
- When there are no more wrinkles in the master, release your finger from the master set switch.
- When the master comes to a stop, be sure to remove the trimmed piece of the master.

If the master cannot be set correctly, it cannot be cut. Remove the master, and set again.

11 Remove the trimmed piece of the master.

IMPORTANT

- Do not forget to remove the edge of the master after cutting. Leaving cut master scraps in the machine may result in machine trouble.

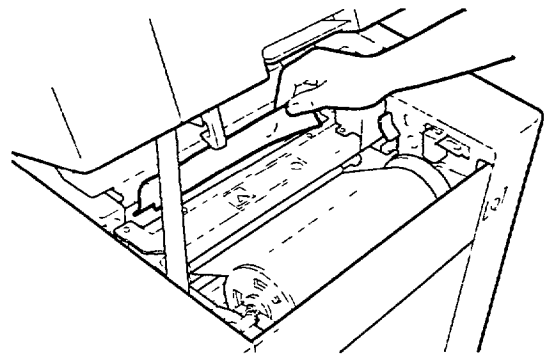

12 Close the top cover gently and press any part of the diagonal line in until it locks.

! WARNING

- Do not remove the cover affixed with Warning Label 1.
- Personnel may be injured by the movable cutter inside the machine.

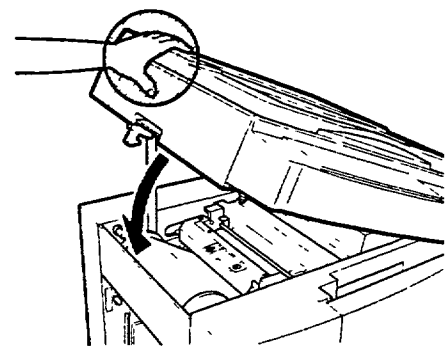

Replacing the Master Ejection Core

- 1 Press the master ejection box release lever.**

The master ejection box will open.

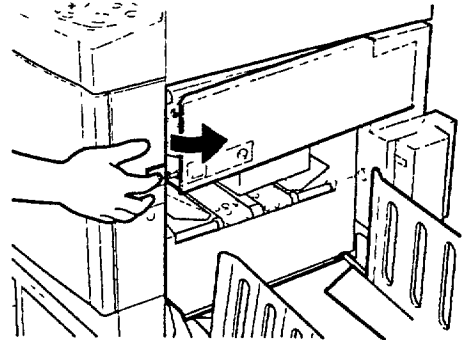

- 2 Open the box all the way until it comes to a stop.**

- 3 Open the lid up by pressing the release lever of the master ejection box lid.**

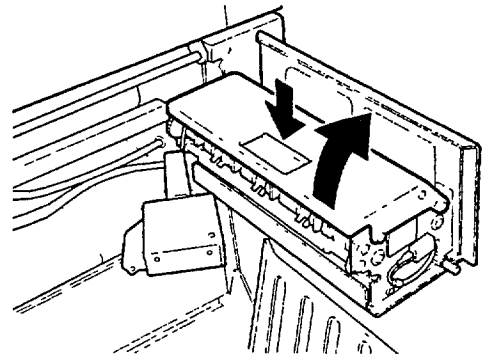

- 4 Pull out the core and discard it while holding the edges of the master ejection core.**

IMPORTANT

- Ink adheres to the master ejection core. Take care to prevent ink from transferring to your clothing.

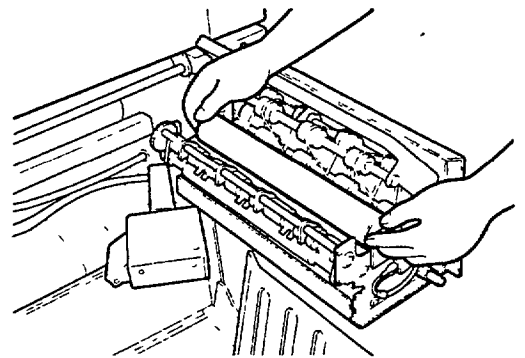

5 Insert a new master ejection core and close the master ejection box lid.

Gently press the master ejection box lid until it locks.

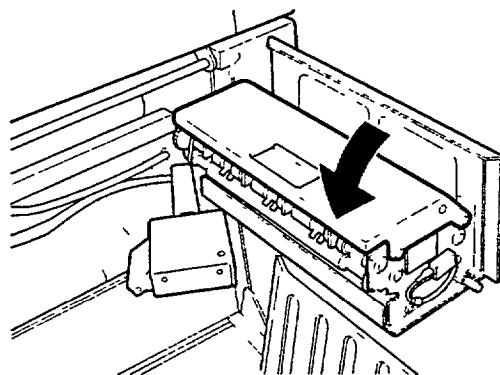

6 Close the master ejection box, and press until it locks.

Press the master ejection box lid until it locks.

Replacing the Drum Unit

Removing the Drum

1 Press the drum rotation switch. Hold the switch down until the drum comes to a stop with a beep.

WARNING

- Do not touch the drum or rollers when you operate the drum rotation switch.
- Do not put your hands or fingers inside the machine while it is operating. Your hands may be pulled in or nipped.

2 Open the front cover towards you.

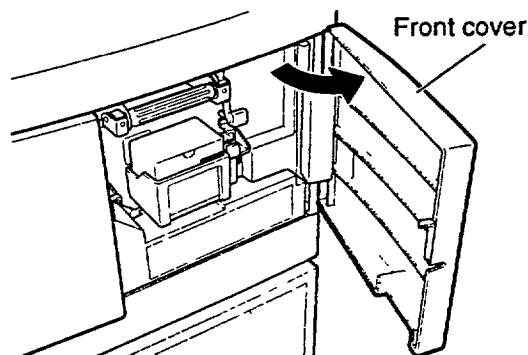
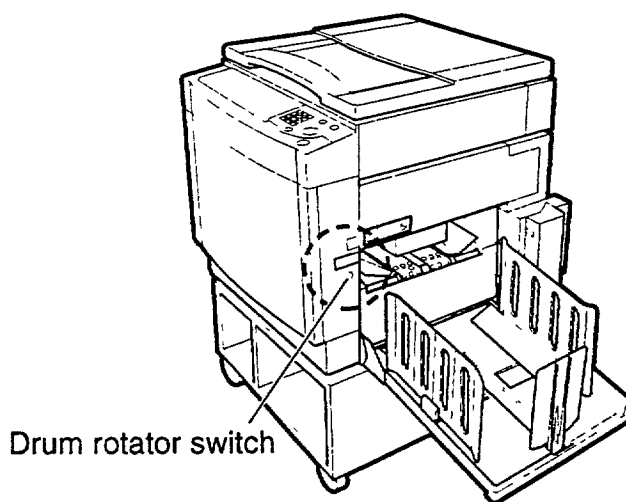

3 Lift up the drum securing lever towards you.

Pull out the drum handle towards you while lifting the lever up, and pull straight out until it comes to a stop.

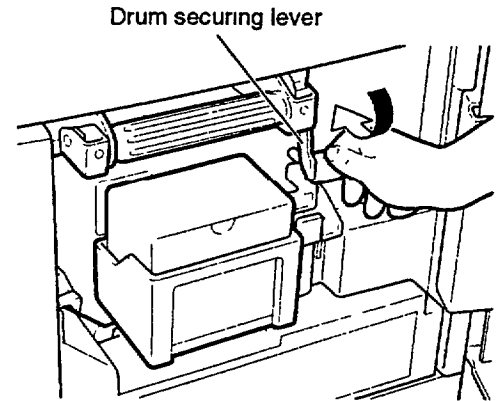

4 Hold the handle on the far end of the drum, and lift the front end of the drum slightly to pull the drum towards you.

IMPORTANT

- Do not touch the drum surface. Ink may transfer to your clothes
- Hold the drum level and place it on a flat, solid surface.

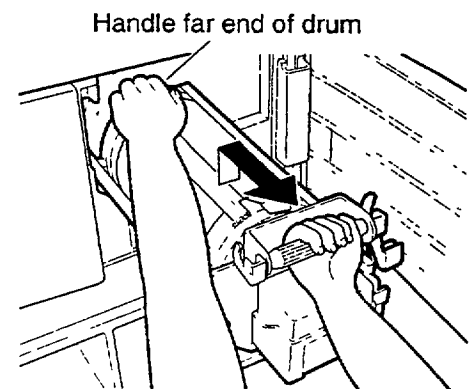

Setting the drum unit

1 Hold the drum level and place the drum guide roller onto the rail in the machine.

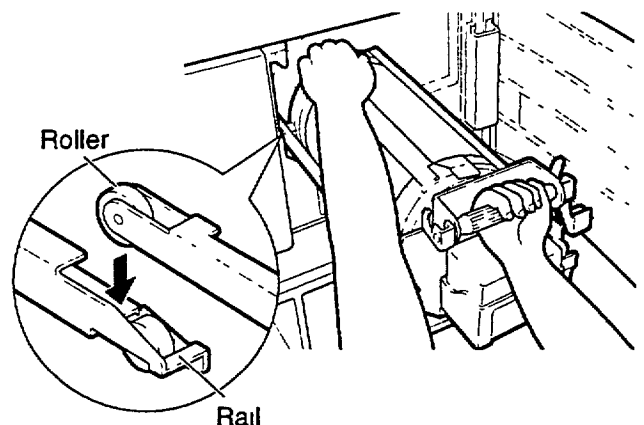

- 2** Release the handle at the far end of the drum and press the drum in for about 10 cm while lifting the front end slightly up.

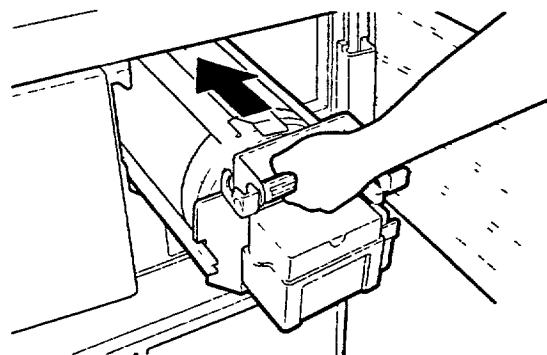

- 3** Hold the drum level and press it in gently until it comes to a stop.

- 4** Lift the drum securing lever towards you while pressing the drum in.

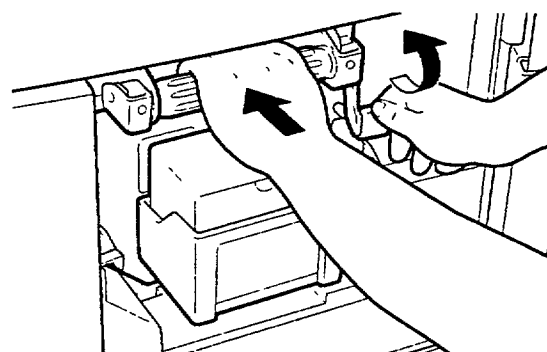

- 5** Lower the drum securing lever.

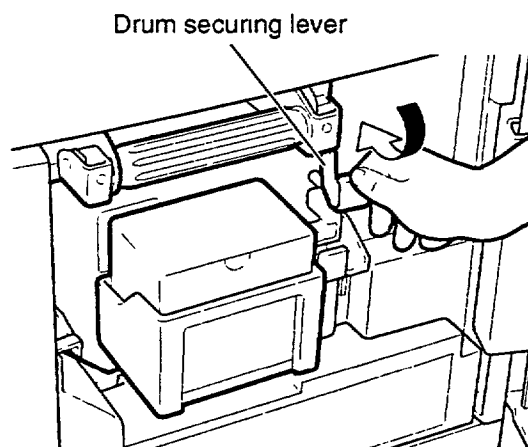

7. Options

Tape cluster

1 Open the tape cluster cover.

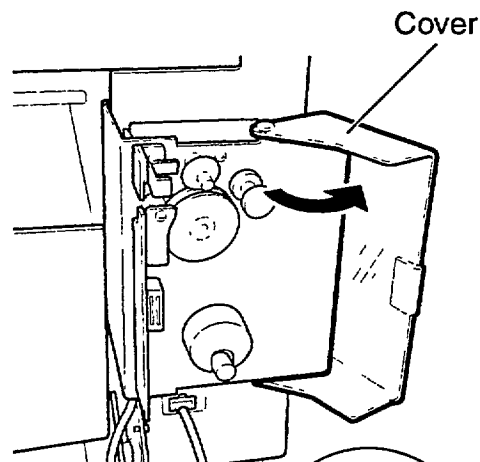

2 Remove the tape core.

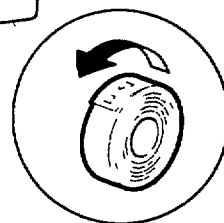

3 Insert the tape while checking for the direction of the tape roll.

4 Insert the tape while lifting the lever up.

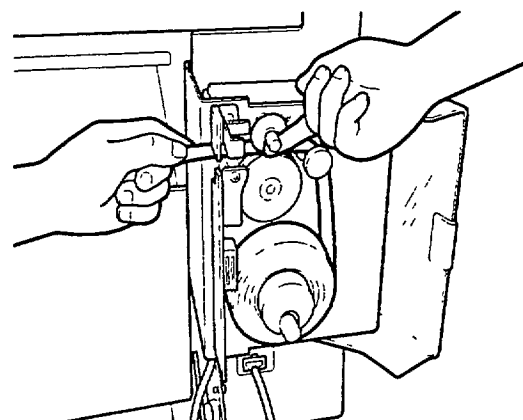

5 Leave end of tape approximately 1 cm out.

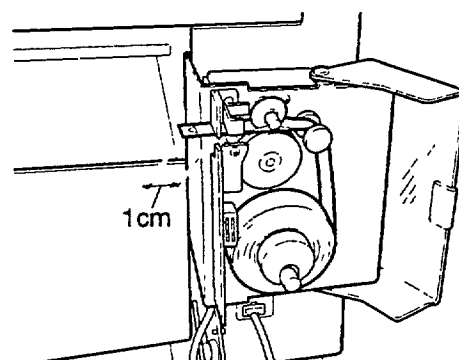

6 Close the cover.

 Chapter 3, "Sectional Printing (dividing sections with tape)"

ADF

Documents that are accepted by ADF

Document thickness:

50 g/m² to 105 g/m² (15 to 28 lb. bond)

Document size:

A3 to A5 (A5 landscape (A5R) cannot be used)

ST to 11"×17" (ST landscape (STR) cannot be used)

Number of documents that can be placed at one time:

11"×17"/ 8.5"×14" (A3/B4).. 15 sheets (80 g/m²)

8.5"×11"/7.2"×10.12"/5.5"×8.5" (A4/B5/A5)

..... 30 sheets (80 g/m²)

LG/11"×17" 15 sheets (20 lb. bond or 80 g/m²)

ST/LT 30 sheets (20 lb. bond or 80 g/m²)

IMPORTANT

- Avoid using the following types of documents:
 - Torn documents or those with holes (for binders, etc)
 - Documents that are extremely curled or folded
 - Documents that are bound by staples or paper clips
 - Documents with carbons or documents that do not feed easily
 - Highly transparent document (OHP films, etc.)
- To print another plate on documents that have plates already made, replace them on the ADF after they are removed from the machine.
- Use documents that are the same size.
- Place only documents of the same size together in the ADF. Placing documents of different sizes together in the ADF may result in erroneous operation.

Platemaking and Printing

When a document is placed on the ADF, the machine will automatically turn to ADF mode and uses documents the ADF first.

III Operation

- 1 Move the sliding guide to match the document size.

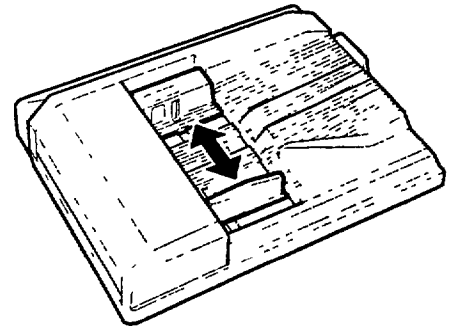

- 2 Place the document with the print side up.

Plates are made from the lowermost placed document

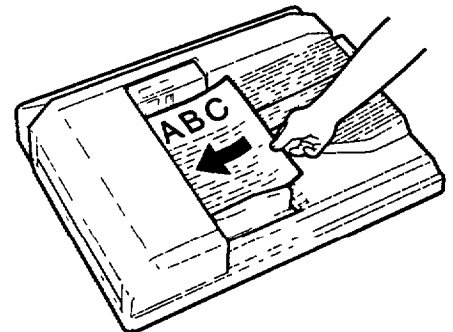

- 3 Make a plate and print following the same procedure as in Chapter 2 "Platemaking and Printing Procedure".



- The machine will automatically make plates and print until all the documents on the ADF are processed.

Key Card Counter

III Function

By selectively using key cards, the number of plates and prints can be managed by personnel or by department.

III Operation



- When the key card must be inserted, the message "PLEASE INSERT CARD" will be displayed on the LCD panel.

DUPLICATOR MESSAGE
PLEASE INSERT CARD



1 Insert the card into the key card counter.

Regular operation is now possible.

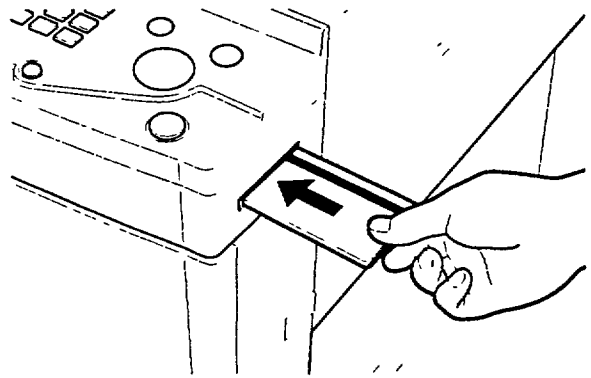

Reference For details on how to use the key card counter, see Key Card Counter Instruction Manual.

Handling Cards

Do not bend or dirty the card.

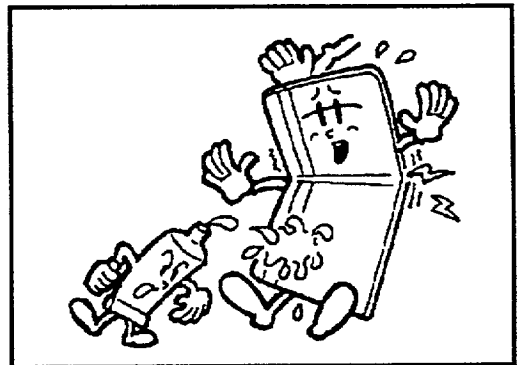

Do not place the card near magnetic fields.

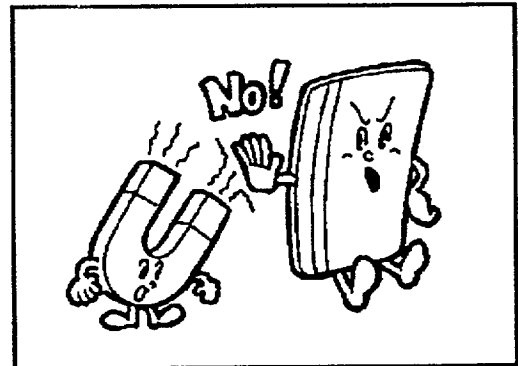

Do not insert anything else into the card entrance besides the specified card.

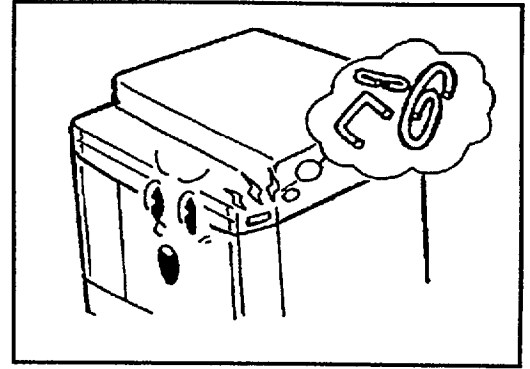

Sorter

The machine collates and separates automatically by using the sort, non-sort and group modes.

Sort mode

Use this mode to print two or more copies from multiple documents. The machine can sort up to 25 sets (50 sets with two sorters connected). When selecting over 26 (51 or more with two sorters connected) prints, the 26th print onwards will be discharged onto the non-sort tray.

IMPORTANT

- The number of sets cannot be entered when the sort mode is selected.

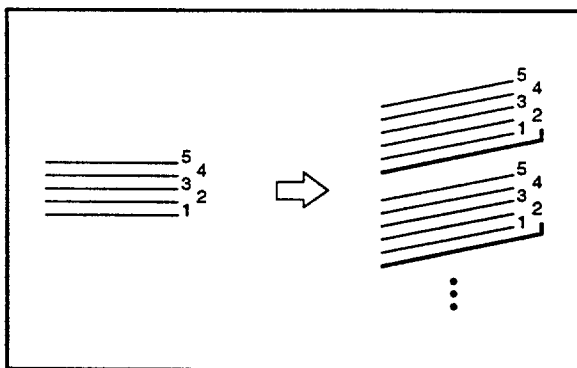

Up to 30 sheets per tray (Note 1)

Group Mode

There are two ways of using the group mode.

○ Grouping according to documents

Prints are separated according to the document when two or more copies are made from multiple documents.

IMPORTANT

- Do not enter the number of sets. When the group mode is selected, no more than 25 sheets per set can be printed.
- See Chapter 3 "Sectional Printing (changing the number of prints with each document)."

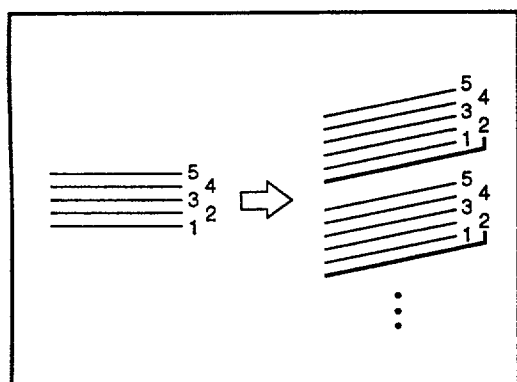

Up to 25 sheets per tray (Note 1)

○ Sectioning prints from one document

When the number of sets is entered, prints from one document are sorted into sets with a specified number of prints. Up to 30 sheets can be printed and up to 25 sets (50 sets with two sorters connected) can be specified.

For details, see Chapter 3 "Sectional Printing (stopping after each set)."

The counter will display in descending number.

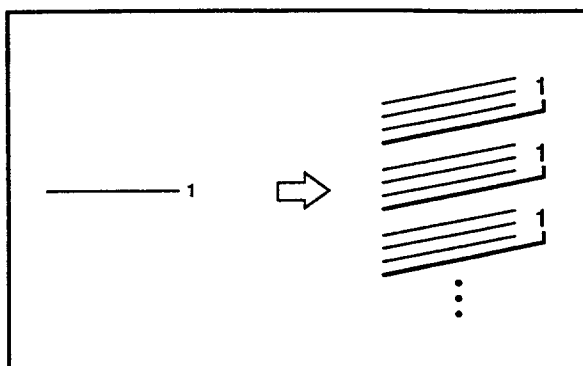

Up to 30 sheets per tray (Note 1)

Note 1: The tray capacity varies depending on the type of paper and curl.

Non-sort Mode

Prints are discharged onto the non-sort tray.

The non-sort tray can hold up to 200 sheets of paper. Printing will stop after 200 sheets. Remove the sheets from the tray, and press the "PRINT" key.



- The number of sets cannot be entered when the non-sort mode is selected.

How to Use The Sorter



- The Sort Mode cannot be changed once the number of copies has been input.

1 Press the [Menu] key.

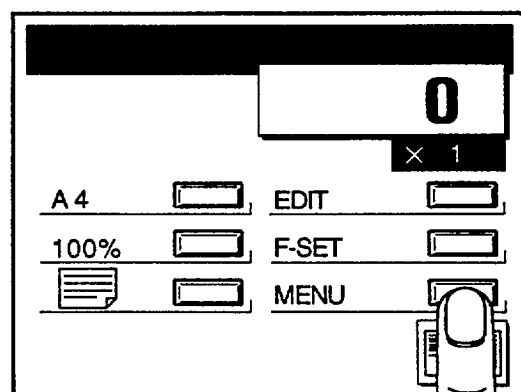

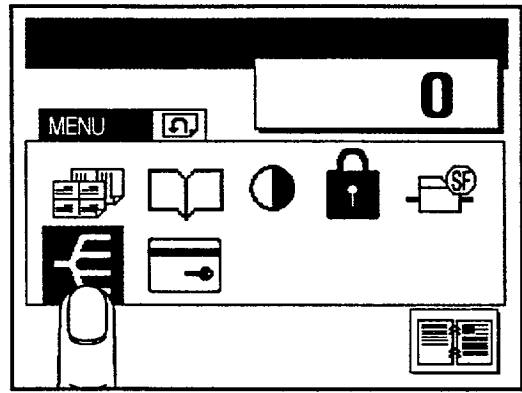

2 Select the Sorter Icon .

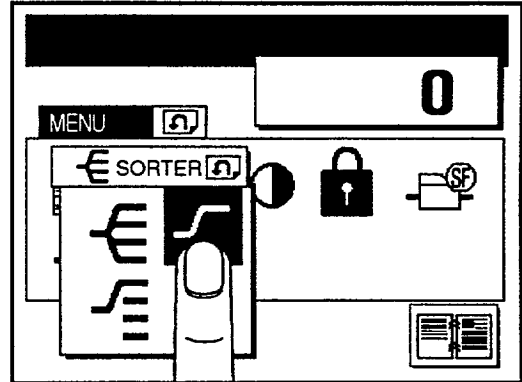

3 Select the Sort Mode.

-  : Nonsort Mode
-  : Group Mode
-  : Sort Mode



4 Press Return  on the Menu Screen.

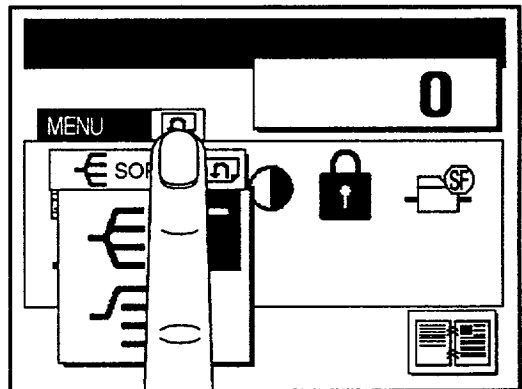

5 Enter the number of prints.

6 Start making plates and Printing.

For details, see Chapter 2 "Platemaking and Printing Procedure."

Interface

Function

This function enables you to make prints of documents directly from on-line data from personal computers.

IMPORTANT

- The IPC board and PC interface kit are required to connect this machine to a personal computer.
- Please contact your service person on information regarding setting and installation.

Operation

1 Make sure that the top menu is displayed.

2 Set the size of the printing paper.

 Chapter 2, "Selecting the Paper Size"

3 Use the print command of the within the application running on the personal computer according to the respective computer manual.

Platemaking and printing will start automatically.

IMPORTANT

- When the I/F indicator lamp is lit, the machine will not operate with the "PLATEMAKING" key.

*When platemaking ends and printing starts, key operations on the control panel is acceptable.

8. Troubleshooting

Power Does Not Turn ON

If the power does not turn ON, check the following.

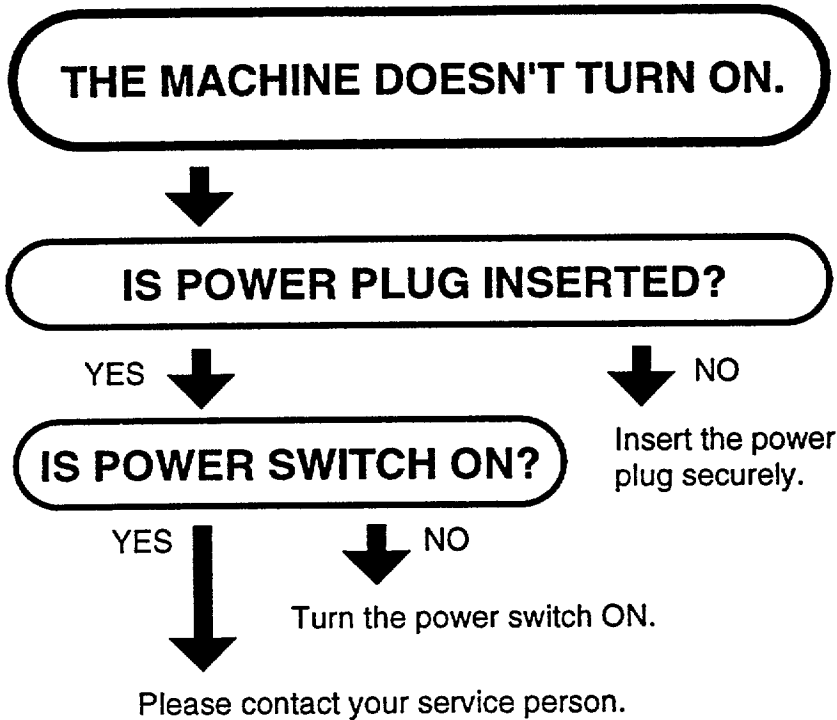

Platemaking/Printing is Not Possible

If platemaking/printing is not possible, check the following.

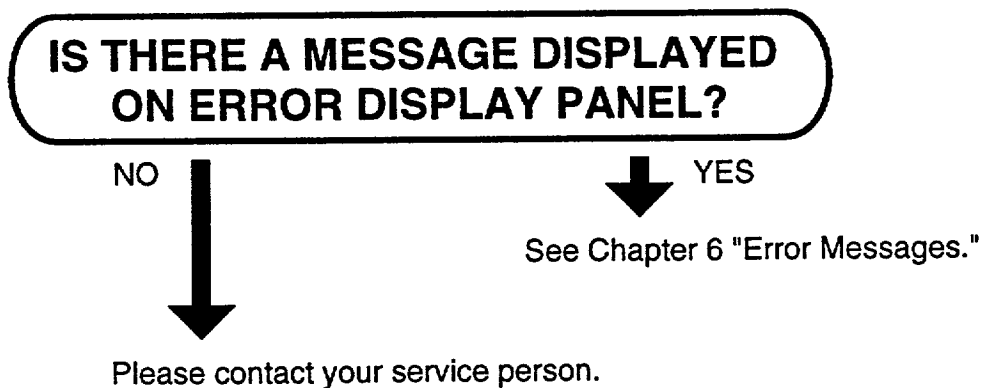

Error Messages

Error messages are displayed in one of two ways, either by text or by number.

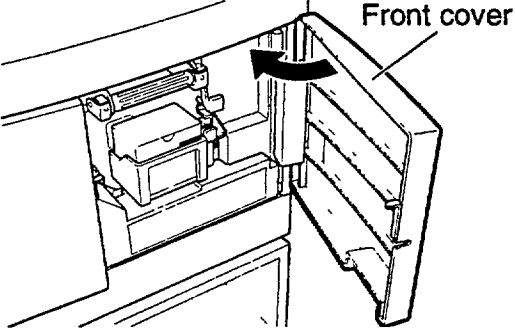
Message	Countermeasures
CHANGE INK	There is no ink. Replace the old ink pack with a new one. For details, see Chapter 4, "Replacing the Ink Pack."
CHANGE MASTER	There is no master. Replace the master roll with a new one. For details, see Chapter 4, "Replacing the Master Roll."
CHANGE MASTER EJECTION CORE	The master ejection core is full. Replace the core with a new one. For details, see Chapter 4, "Replacing the Master Ejection Core."
ADD PAPER	There is no printing paper. Add more paper. For details, see Chapter 2, "Setting the Paper."
NO DRUM	There is no drum. Set the drum unit on the machine. For details, see Chapter 4, "Drum Unit."
FRONT COVER OPEN	Front cover is open. Close the cover. 
TOP COVER OPEN	Top cover is open. Close the cover. Press a section of diagonal line until it locks.
PAPER JAM ON THE FEEDER SIDE	Paper jam on the feeder side. Check the feeder side and remove the jammed paper. Follow the instructions on Chapter 8, "Paper Jam (feeder side)."
PAPER JAM ON THE EJECTION SIDE	Paper jam on the ejection side. Check the ejection side and remove the jammed paper. Follow the instructions on Chapter 8, "Paper Jam (ejection side)."
PLATE EJECTION ERROR	There is an old master on the drum. Remove all the masters on the drum. For details, see Chapter 8, "Master is Not Ejected."
MASTER SETTING ERROR	There is an error during master setting. Open the top cover and remove the master that is left in the machine. For details, see Chapter 8, "Master Set Incorrectly."
ADF PAPER JAM	The document is jammed on the ADF. Remove the jammed document in accordance with the ADF instruction manual.

Message	Countermeasures
PLEASE WAIT	Printer is not ready Please wait with the power ON If the message remains after a few minutes, turn the power OFF and contact your service person
PLEASE INSERT CARD	Insert the specified card into the key card counter For details, see the Key Card Counter Instruction Manual.
PLEASE PLATE MAKING	Master set error or Confidential Safeguard function is ON The message will be displayed when the PRINT or "TEST PRINT" key is pressed without making the master Make master
SORTER JAM 1	There is a paper jam at the A sorter passage. Remove the jammed paper. For details, see the Sorter Instruction Manual.
SORTER JAM 2	There is a paper jam at the B sorter passage Remove the jammed paper For details, see the Sorter Instruction Manual.
SORTER JAM 3	There is a paper jam at the B sorter passage Remove the jammed paper. For details, see the Sorter Instruction Manual
SORTER DOOR OPEN	The sorter door is open Close the door For details, see the Sorter Instruction Manual
STAPLER DOOR OPEN	The sorter door is open Close the door For details, see the Sorter Instruction Manual.
NO STAPLES	There are no more staples in the A sorter Add more staples. For details, see the Sorter Instruction Manual
NO STAPLES 2	There are no more staples in the B sorter Add more staples For details, see the Sorter Instruction Manual
ONLINE MODE	The "PLATEMAKING" key was pressed when the I/F lamp was lit indicating that the machine was in the online mode Press the "INTERFACE" key After making sure that the I/F lamp goes out, press the "PLATEMAKING" key If the machine is performing a job in the online mode, wait for the job to be
EXXX	Turn the power OFF and back ON again. If the machine does not operate normally, call the service person, and describe the error code and situations that led to it as clearly as possible.

If Paper Runs Out during Printing

If paper runs out during printing, printing stops and the paper tray is lowered automatically.

 Chapter 2, "Setting the Paper"

To add more paper to an almost empty stack during printing

- 1** Press the "STOP" key.
Stop printing.

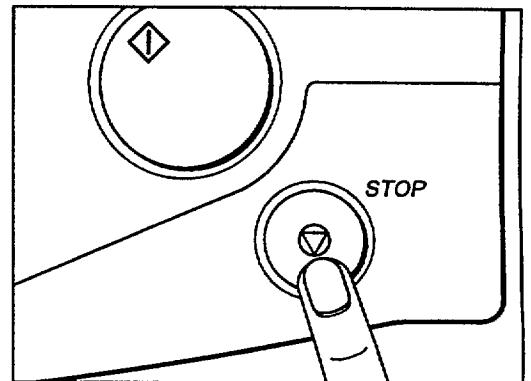

- 2** Press the paper tray descend switch continuously. Release the switch when the paper tray reaches the proper height.

The paper tray will stop.

Paper tray descending switch

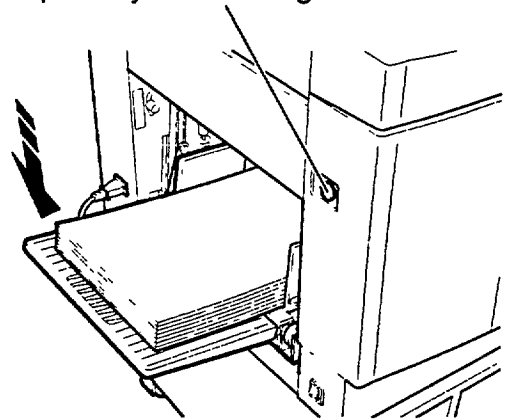

IMPORTANT

- If the sheet is still in the feed roller ring, pull it out and align it with the stack.

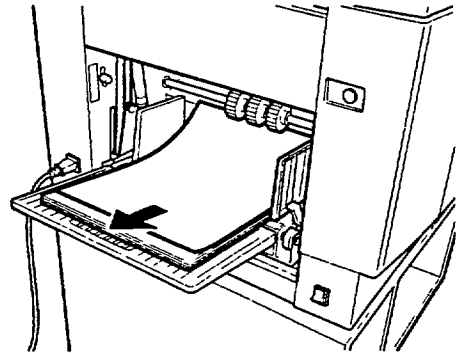

- 3** Align the stack to be added and place it on top of the existing stack. Press the stack lightly toward the machine.

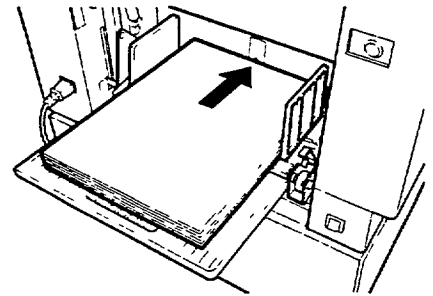

- 4** Press the "PRINT" key.

The paper tray will rise automatically and printing will resume.

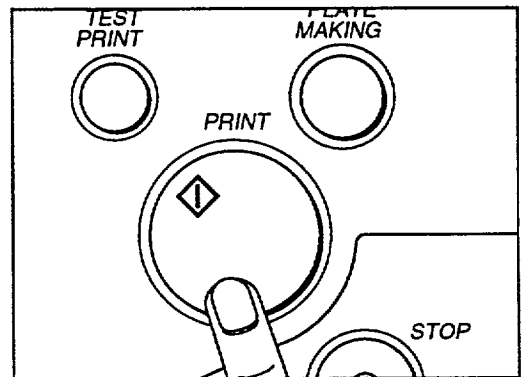

To replace with a different size of paper

1 Press the "STOP" key.

Printing will stop.

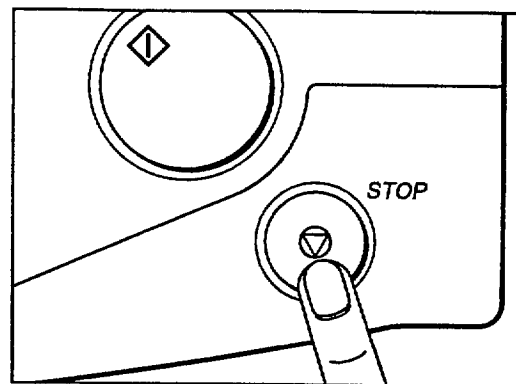

2 Press the paper tray descend switch continuously. Release the switch when the paper tray is at the proper height.

The paper tray will stop.

Paper tray descending switch

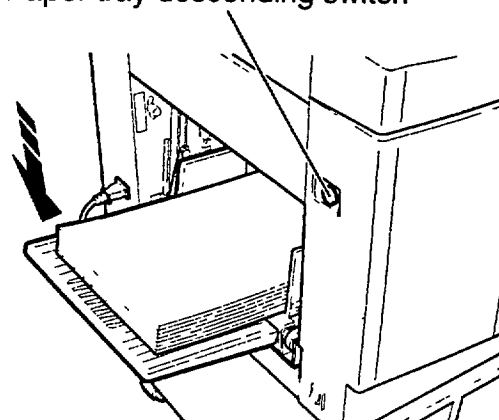

IMPORTANT

- If the sheet is still in the feed roller ring, pull it out and align it with the stack.

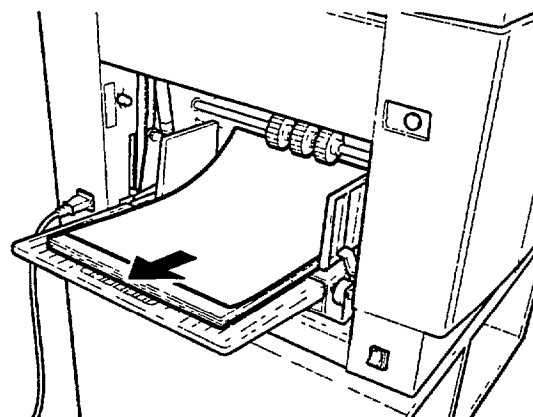

3 Remove paper from the paper tray.

The paper tray will automatically descend.

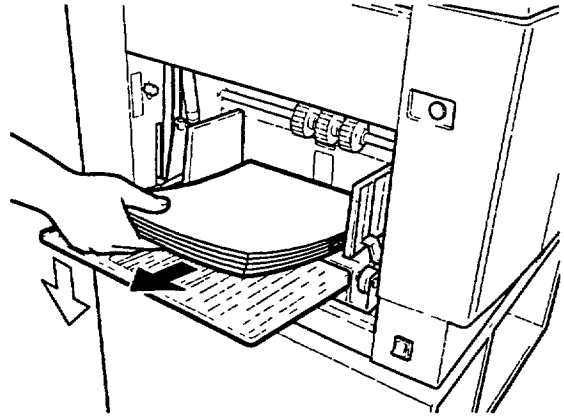

4 When the paper tray comes to a stop, reset the paper size.

5 Press the "PRINT" key.

The paper tray will rise automatically and printing will resume.

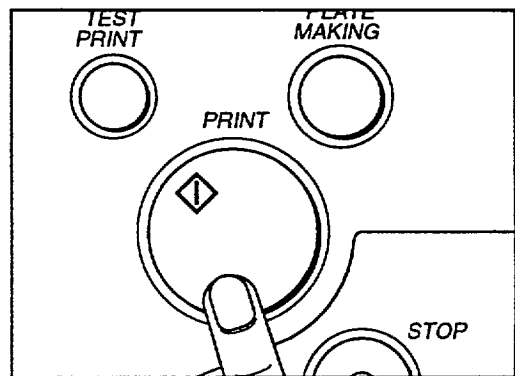

Paper Jam (feeder side)

If the message "PAPER JAM ON THE FEEDER SIDE" is indicated in the error display panel, check the feeder side and remove the jammed paper by following the procedure below.

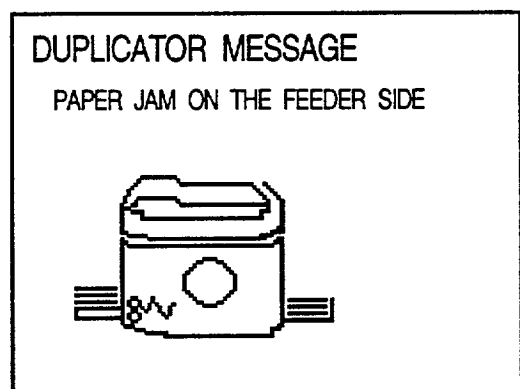

1 Press the paper tray descending switch to lower the paper tray slightly.

The paper tray is lowered for the time that the switch is pressed.

Paper tray descending switch

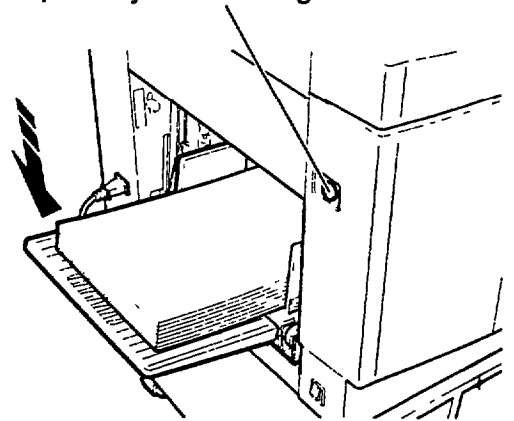

2 Pull out the jammed paper as shown in the diagram.

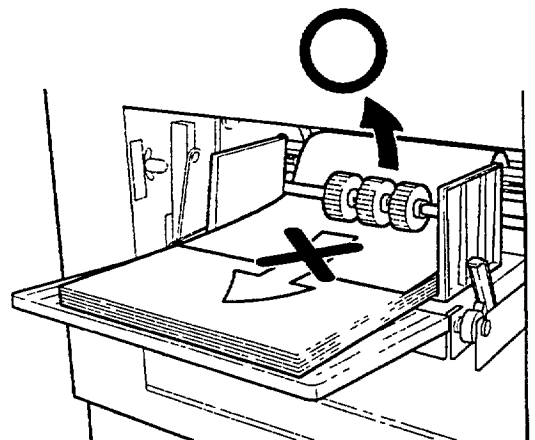

3 Press the DRUM ROTATOR switch until the drum comes to a stop with a beep.

! WARNING

- Do not touch the drum or rollers when you operate the drum rotation switch.
- Do not put your hands inside the machine while it is operating. Your hands may be pulled in or nipped.

Drum rotator switch

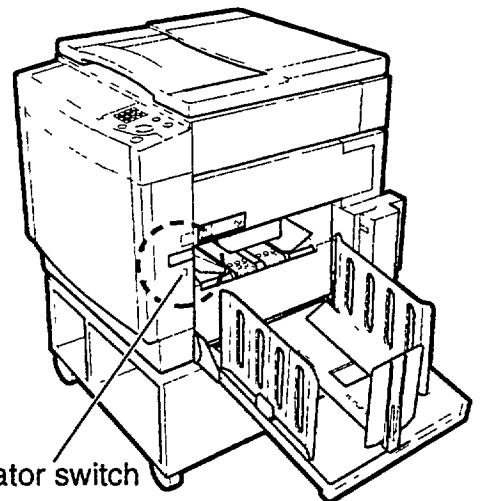

Paper Jam (ejection side)

If the message "PAPER JAM ON THE EJECTION SIDE" is indicated in the error display panel, check the ejection side and remove the jammed paper by following the procedure below.

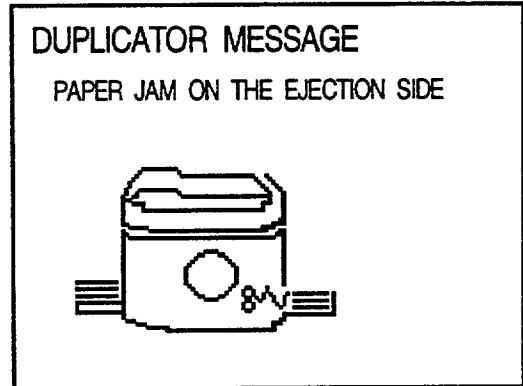

- 1 Press the master ejection box release lever.**

The box will open towards you.

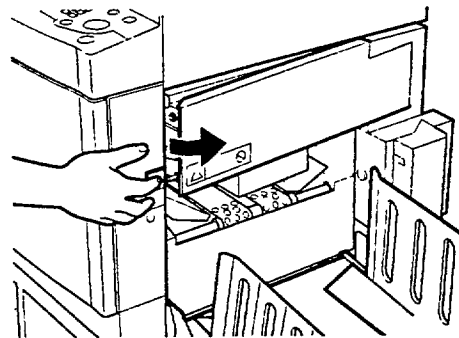

- 2 Open the box until the box comes to a stop.**

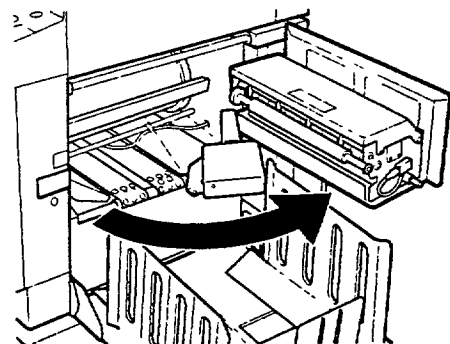

3 Remove the jammed paper.

Discharge paper printed halfway by pressing the DRUM ROTATOR switch.

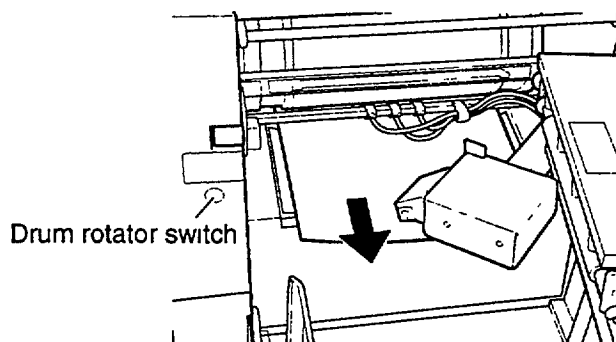

Paper Adhering to Drum

1 Press the drum rotator switch to find the edge of the paper, then stop the drum at the position shown in the diagram.

! WARNING

- Do not touch the drum or rollers when you operate the drum rotation switch.
- Do not put your hands inside the machine while it is operating. Your hands may be pulled in or nipped.

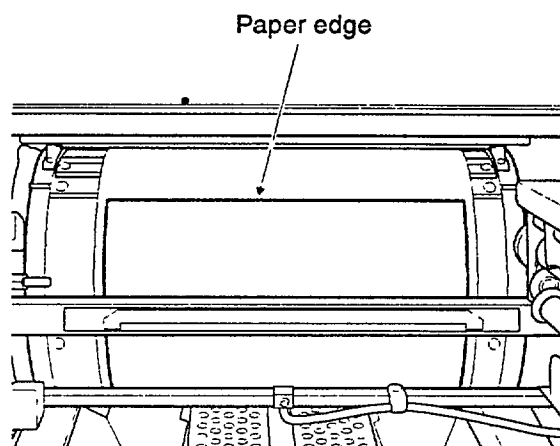

2 Peel off the edge of the paper from the drum.

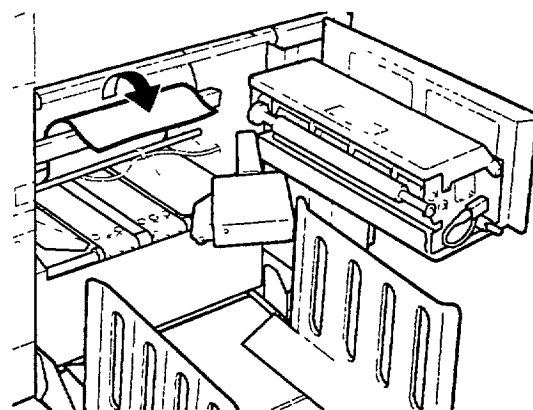

3 Pull the paper toward the ejection side while pressing the drum rotator switch to peel the paper off.

IMPORTANT

- Make sure that the peeled paper does not stick to your clothing.

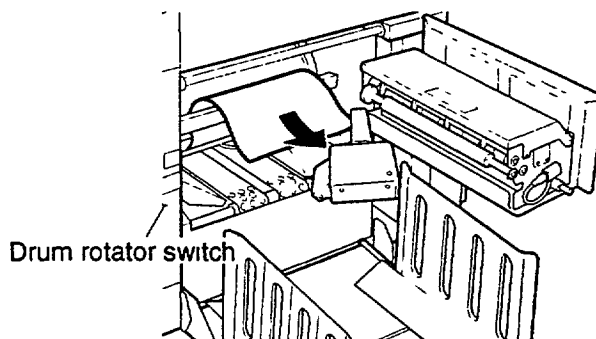

4 Hold the drum rotator switch down until the drum comes to a stop with a beep.

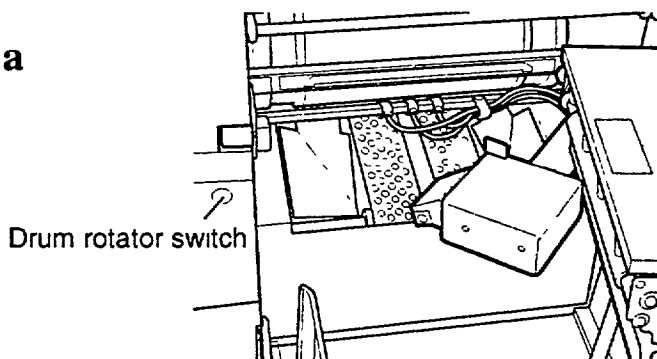

5 Close the master ejection box until it locks.

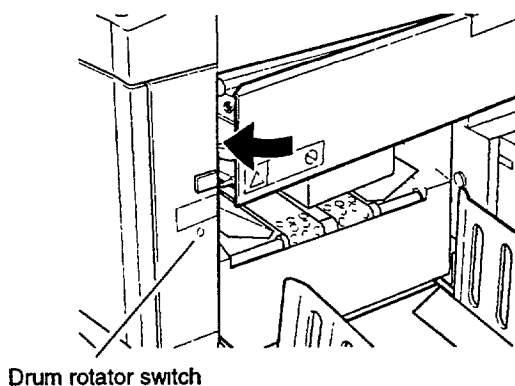

6 Make another plate.

Master is Not Ejected

When this message is displayed on the LCD panel, there is an old master on the drum. Remove it by following the procedure below.

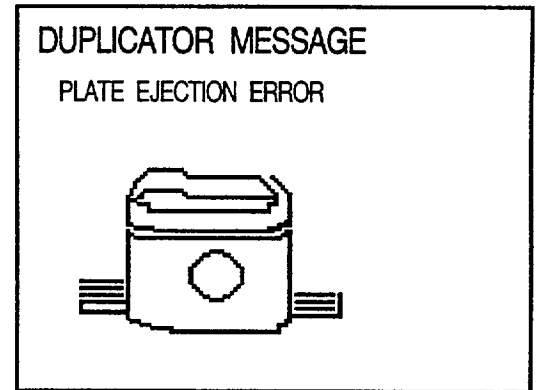

- 1 Press the master ejection box release lever.

The box will open towards you.

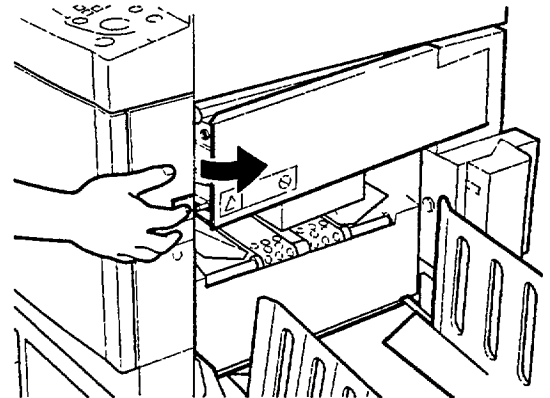

- 2 Open the box until it comes to a stop.

- 3 Press the drum rotator switch to stop the drum at the position shown in the diagram.

WARNING

- Do not touch the drum or rollers when you operate the drum rotation switch.
- Do not put your hands inside the machine while it is operating. Your hands may be pulled in or nipped.

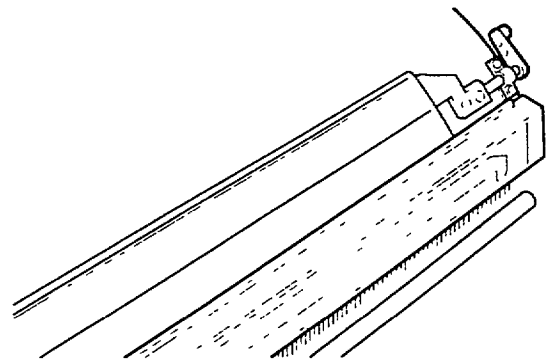

4 Lift the lever towards you.

The master clamp will open and the edge of the master will be released from the clamp. If the master is stuck, release it manually.

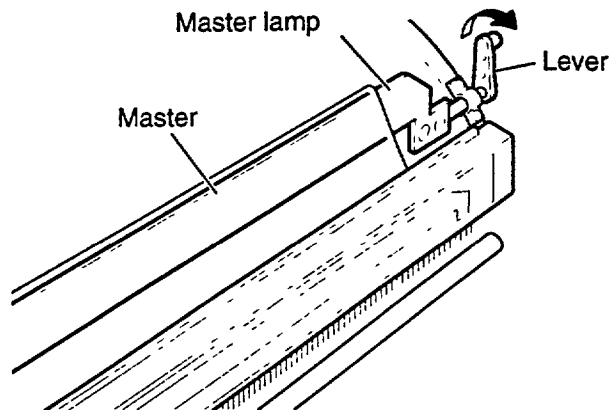

5 Return the lever to its original position.

6 Pull the front end of the master towards you and press the drum rotator switch intermittently.

Hold the switch down until the master peels off.



- Discard the old master making sure that it does not touch your clothing.

7 Hold the drum rotator switch down until the drum comes to a stop with a beep.

8 Close the master ejection box until it locks.

9 Make another plate.

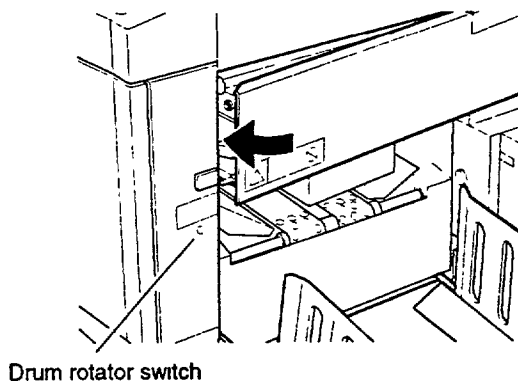

Master Set Incorrectly

If the message "MASTER SETTING ERROR" is indicated in the error display panel, remove the master and remake the plate by following the procedure below.

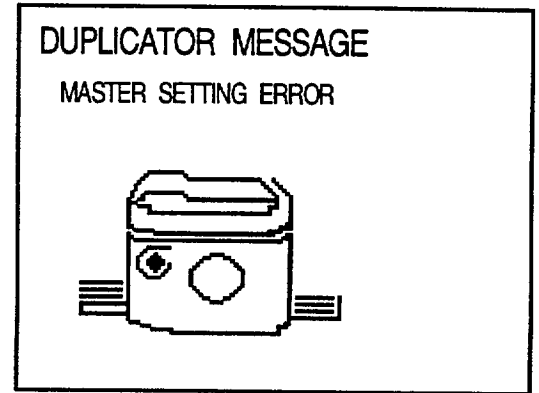

- 1** Raise the top cover release lever to open the top cover.

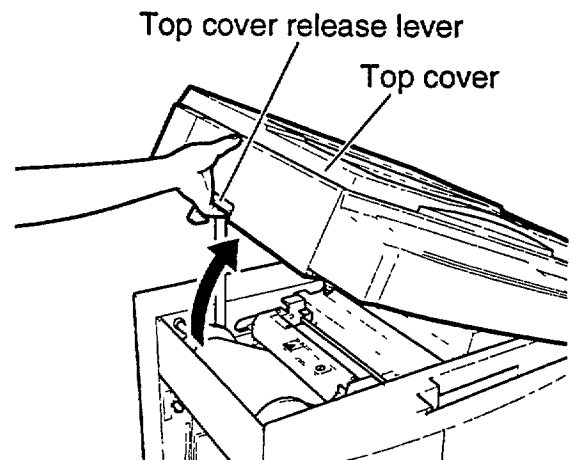

- 2** Remove the master left in the machine.

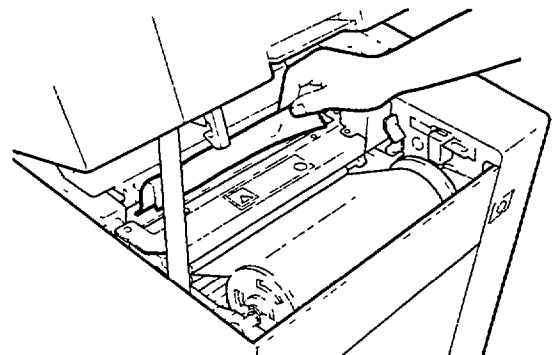

3 Close the top cover gently and press it until it locks.

4 Make sure that the error display panel is not lit.

5 Make the plate and print again.

IMPORTANT

- The message "CANNOT PRINT" will be displayed when the "PRINT" key is pressed without platemaking being carried out.

9. Specifications, Maintenance

Product name/model No.	Duprinter DP-43E	Duprinter DP-33E	Duprinter DP-31E
Model	Floor model		
Platemaking method	Thermal digital platemaking		
Platemaking interval	17 seconds (A3, same size)	15 seconds (A4, same size)	
Resolution	15 7 dots/mm (400 dpi)		11.8 dots/mm (300 dpi)
Scanning method	Fixed document		
Printing method	Stencil printing		
Document type	Sheet, Book (less than 2 kg)		
Document size	Max 297 mm × 432 mm		
Printing area	Max. 290 mm × 410 mm	Max. 250 mm × 350 mm	
Feeding capacity	1000 sheets (64 g/m ² , top-grade paper)		
Stacking capacity	1000 sheets (64 g/m ² , top-grade paper)		
Paper size	Max 297 mm × 432 mm (A3: 11" × 17") Min 100 mm × 150 mm (postcard)		
Paper thickness	53 g/m ² to 210 g/m ² (45 kg to 180 kg)		
Printing speed	120 sheets/min. (45 to 120 sheets/min, 5 step adjustment)		
Print enlargement/reduction A, B size model	Same size 100% Fixed zoom ratios 70, 81, 86, 115, 122, 141% Print with border 94% Free zoom range 50 to 300% Auto zoom 70, 81, 86, 115, 122, 141%		
Inch size model	Same size 100% Fixed zoom ratios 64, 74, 77, 121, 129, 141% Print with border 94% Free zoom range 50 to 300% Auto zoom 67, 74, 77, 121, 129, 141%		
Printing position adjustment	Vertical ±15 mm Horizontal ±10 mm		
Image modes	Text/photograph mode (fine text/screen/dark photo) Multiple printing (2, 4, 8 up) Book shadow eraser		
Ink supply method	Complete automatic control (600 cc, 1000 cc)		
Color printing	Drum unit exchange method		
Master feeder	Roll master automatic feed		
Plate ejection	Complete automatic ejection plate rolling method		
Editing Functions	Trimming Makeup Photograph Mode, Reversing, Masking, Outline Type, Halftones, Background Designs, Reversing Background Designs, Mask Area Exchange, Additional Makeup		

Contrast control	Platemaking density 5 step adjustment Printing density 3 step adjustment
Display panel	320 × 240 dots, full dot matrix LCD with Touch Panel (pressure sensitive) input capabilities *Inputting can be performed using either one's finger or a special input pen.
Other standard functions	OK monitor (graphical display, Kanji characters/illustration display) Memory (2 channels) Confidential Safeguard Function Entry of different number of prints or sets Special function
Options	ADF (Automatic Document Feeder) Drum unit Keycard counter (built-in type) Tape cluster Sorter PC interface kit
Power source 120 VAC model	120 VAC 60 Hz, 5 A
230 VAC model	230 VAC 50 Hz, 2.5 A
Power consumption	230 W (during platemaking), 110 W (during 3-speed printing), 30 W (during standby)
Size Operational Idle	1288 mm (W) × 665 mm (D) × 652 mm (H) 675 mm (W) × 655 mm (D) × 652 mm (H) (cabinet height 350 mm)
Weight	Machine 96 kg Base 12 kg
Operating temperature	10°C to 30°C
PC interface kit	For installing printer driver in PC • Windows 3.1 compatibility Free version upgrade to Windows95 • Macintosh compatibility (System 7.1 or later) I/F board in main unit (on-line set III board unit) SCSI cable (4 m) (double-ended half-pitch bellows connector)

Note: Specifications are subject to change without notice.

Warranty and Maintenance Service

1. Check the particulars and contents of the Warranty and store in a safe place.
2. The free-of-charge replacement warranty period of this Warranty is one year from date of purchase.
Note that the warranty period expires when the total number of prints reaches 1,000,000 even within the year of purchase.

Note: Repairs necessitated by the failure of the user to adhere to the operating methods and precautions set forth in this manual will not be performed free of charge even during the warranty period.

The following parts are consumable, and as such, are not replaced free of charge even during the warranty period.

Consumable Items

Paper Feed Rollers
Paper Separator Unit
Indicator Lamps

Repair parts for this printer will be maintained for a minimum of seven years following the termination of production.
For details, contact your agent or service representative.

3. After the free-of-charge replacement warranty period has expired, the following two maintenance service systems are provided to ensure satisfactory operation and running of your machine.

For details, contact your agent or service representative.

• **Yearly Maintenance Agreement System**

Maintenance and servicing is carried out when machine trouble occurs according to the conditions of a yearly maintenance agreement concluded between the user and the manufacturer.

This agreement covers replacement of parts.

• **Spot Service System**

Maintenance and servicing is carried out when requested by the user.

Quick Operation Guide

● Preparations

- Open the supplemental paper tray.

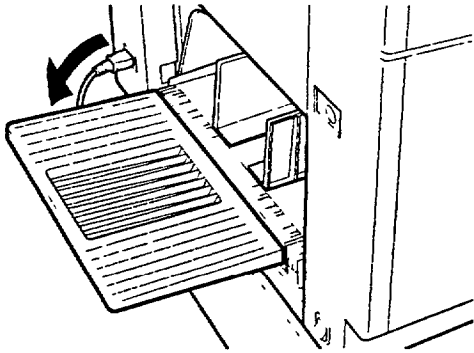

- Raise the paper guide lock lever.

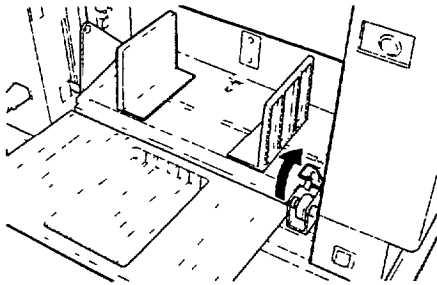

- Set the paper guides to the size of the paper to be used.

- Place a stack of aligned sheets in the feeder tray

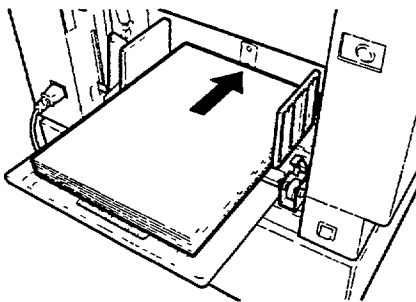

- Lower the paper guide lock lever.

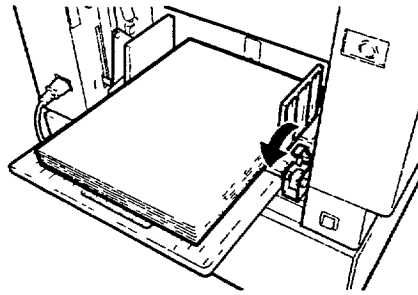

- Pull out the paper stacker base.

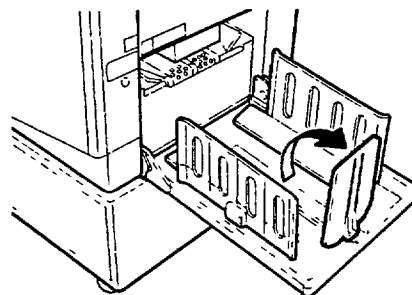
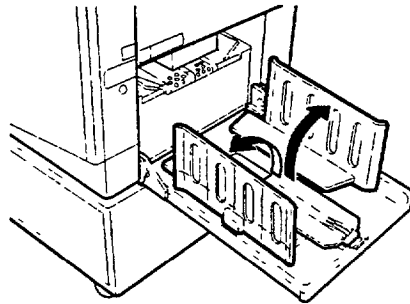
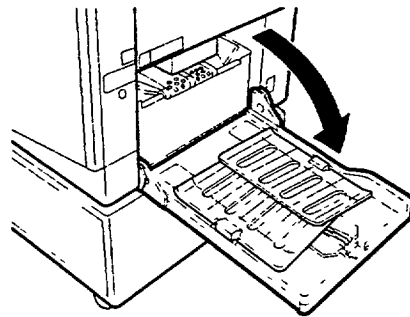

- Raise the paper stacker guides and paper stopper, and adjust them to the size of the printing paper.

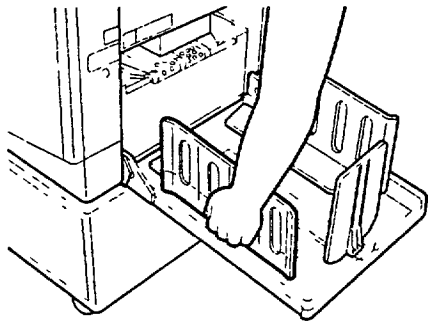

- Turning the power ON.

After a while, the following is displayed on the LCD panel.

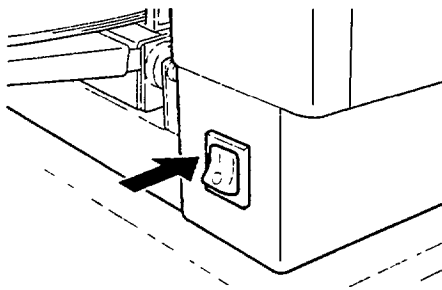

●Platemaking

- Open the document cover and set the document in place.

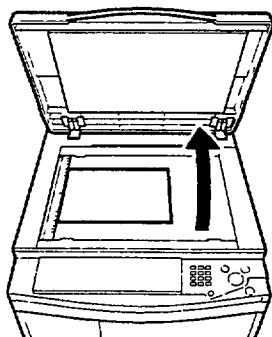

- Select the paper size.

- Make the required settings on the control panel.

The following must be set before platemaking:

Text / photograph mode, paper selection, X94%, zoom factor (including auto zoom, zoom), fine text / screen, multiple printing, dark photo

- Press the "PLATEMAKING" key.

Make a test print.

- Check the finished plate. Adjust the plate darkness, printing speed and other settings as required.

TIP To make another test print, press the "TEST PRINT" key.

● Print

- Enter the number of prints on the key pad.

TIP To change the number of prints, press the "CLEAR" key, and enter the desired number of prints.

- Press the "PRINT" key.

TIP To stop the machine midway during operation, press the "STOP" key.